

# INVISI BRAKE

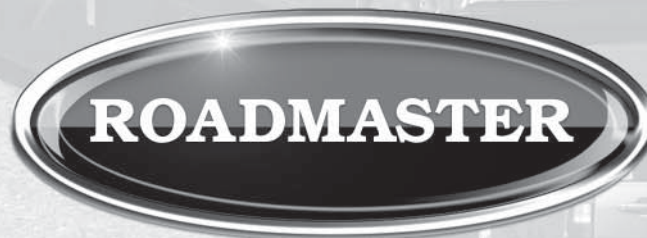

Part number 8700

## Installation Instructions



Towing and Suspension Solutions

ROADMASTER, Inc. • 6110 NE 127th Ave. • Vancouver, WA 98682  
• 800-669-9690 • Fax 360-735-9300

© 2011 ROADMASTER, Inc. All rights reserved. 854649-07 09/11

## InvisiBrake specifications

Controller height .....	2¾ inches
Controller width .....	8¾ inches
Controller length .....	8¾ inches
Voltage.....	12 volts DC
Fuse size .....	20 amp
Operating temperature range	
.....	-2° to +150° F (-19° to +66° C)
Maximum amperage draw .....	10.8 amps
Idle amperage draw.....	6 mA
Battery recharging rate.....	up to 2 amps
Approximate maximum air pressure.....	80 psi

## Required tools

- drill with ½" and 5/16" bits (The ½" bit is only necessary if there is no pre-existing hole through the firewall; the 5/16" bit is necessary if you will drill a hole through the motorhome dashboard for the LED monitor light)
- test light
- multi-meter
- wire strippers or crimpers
- 7/16", 1/2" and 9/16" wrenches
- 5/32" Allen wrench
- adjustable wrench
- 5/16" and 3/8" drivers

## If you are a professional installer...

...return these instructions to the owner, for the owner's future reference.

## Table of contents

Components .....	1
Wiring diagrams.....	2
Warnings and cautions.....	3
Installation instructions.....	4-13
Plan the installation.....	4-6
Begin the installation –	
Attach the clamp, pulley and bracket.....	7
Adjust the cable .....	8
Route the cable housing	
and attach the air line .....	8
Attach the vacuum line.....	8-9
Install the break away system;	
attach the power and ground wires .....	9-10
Check the existing wiring .....	10
Attach the six-wire harness;	
attach the controller .....	10-11
Install the motorhome monitor system;	
seal the firewall .....	11-12
Test the system .....	13

## WARNING

**Read all instructions before installing or operating InvisiBrake. Failure to understand how to install or operate InvisiBrake could result in property damage, personal injury or even death.**



## IMPORTANT NOTICE!

### Safety Definitions

These instructions contain information that is very important to know and understand. This information is provided for **safety** and to **prevent equipment problems**. To help recognize this information, observe the following symbols:

### WARNING

**WARNING indicates a potentially hazardous situation which, if not avoided, could result in property damage, serious personal injury, or even death.**

### CAUTION

**CAUTION indicates a potentially hazardous situation which, if not avoided, may result in property damage, or minor or moderate personal injury.**

### CAUTION

**CAUTION used without the safety alert symbol indicates a potentially hazardous situation which, if not avoided, may result in property damage.**

### NOTE

*Refers to important information and is placed in italic type. It is recommended that you take special notice of these items.*

# Components

- | part number | description   |
|-------------|---|
| 1           | 945201-00 .....InvisiBrake controller, complete   |
|             | 452121.....InvisiBrake compressor only (not shown)  |
|             | 452112.....InvisiBrake kip valve only (not shown)   |
|             | 452110.....InvisiBrake circuit board only (not shown)                                     |
|             | 450431-3 .....InvisiBrake regulator only (not shown)                                      |
|             | 450431-10.....plastic bonnet ring for regulator   |
| 2           | 452109.....cable only   |
| 3           | 452109-10.....air cylinder only   |
| 4           | 452104.....pulley only  |
| 5           | 452140.....cable anchor bracket   |
| 6           | 945202-00 .....brake pedal clamp<br>(with mounting nuts and bolts)                        |
| 7           | 450008 .....monitor wire patch cord   |
| 8           | 450008-15 .....car side monitor wire,<br>15 feet long (not shown)                         |
| 9           | 450008-50.....motorhome side monitor wire,<br>50 feet long (not shown)                    |
| 10          | 945203-00.....four-wire harness:<br>break away, power and ground                          |
| 11          | 8602 .....break away cable  |
| 12          | 650898 .....break away switch, pin and ring<br>200200-20.....break away pin and ring only |
| 13          | 300065-00.....motorhome monitor LED   |
| 14          | 451350.....audio signal circuit board   |
| 15          | Vacuum check valves   |
|             | 452141 .....3/8" vacuum check valve   |
|             | 452142.....1/2" vacuum check valve  |
| 16          | 450701.....1/8" air line (not shown)  |
| 17          | 450700 .....1/4" nylon vacuum line (not shown)  |
| 18          | 452111 .....1/4" rubber vacuum hose, one foot (not shown)                                 |
| 19          | 452137.....3/8" rubber vacuum hose (not shown)  |
| 20          | 452136.....1/2" rubber vacuum hose (not shown)  |
| 21          | 452118 .....3/8" vacuum line tee  |
| 22          | 452116 .....1/2" vacuum line tee  |
| 23          | 945204-00.....four-wire flat harness: towed lighting                                      |

(Components not shown to scale)

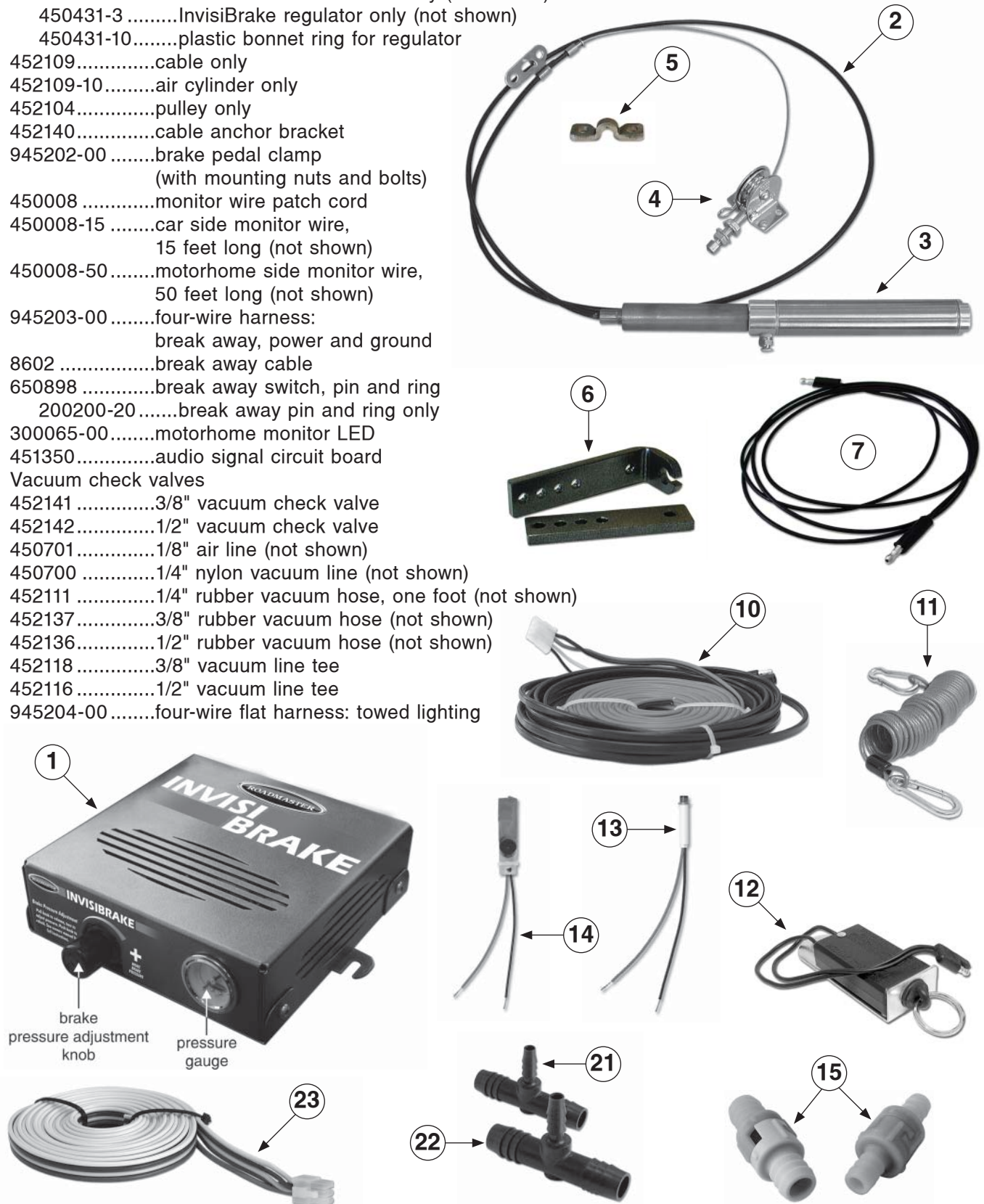

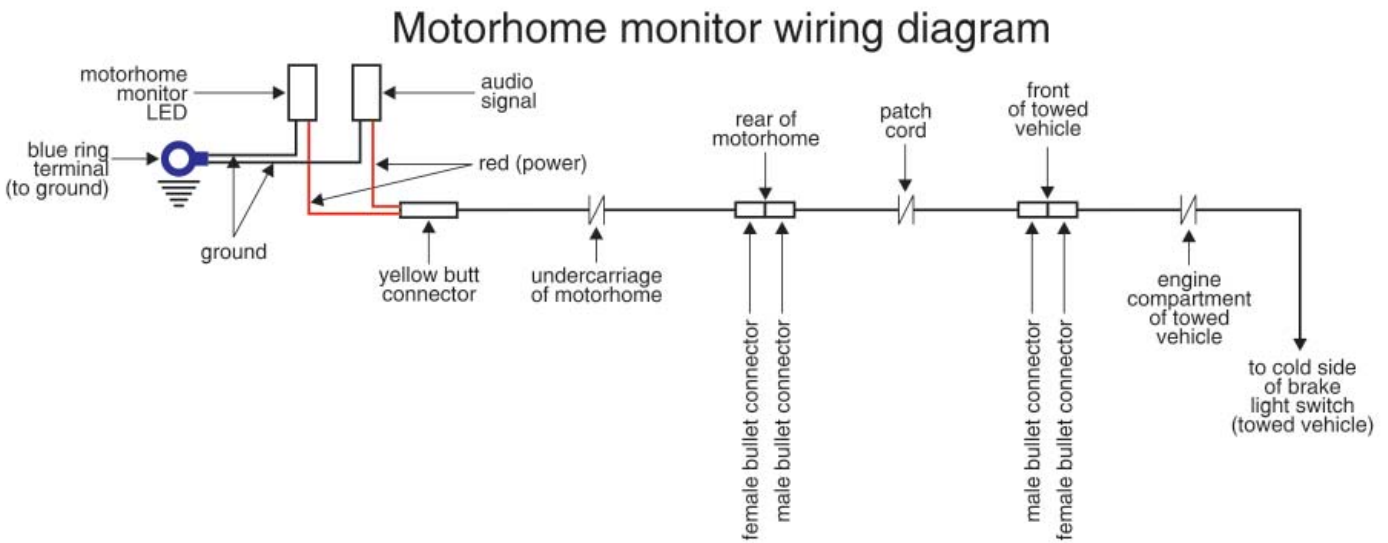
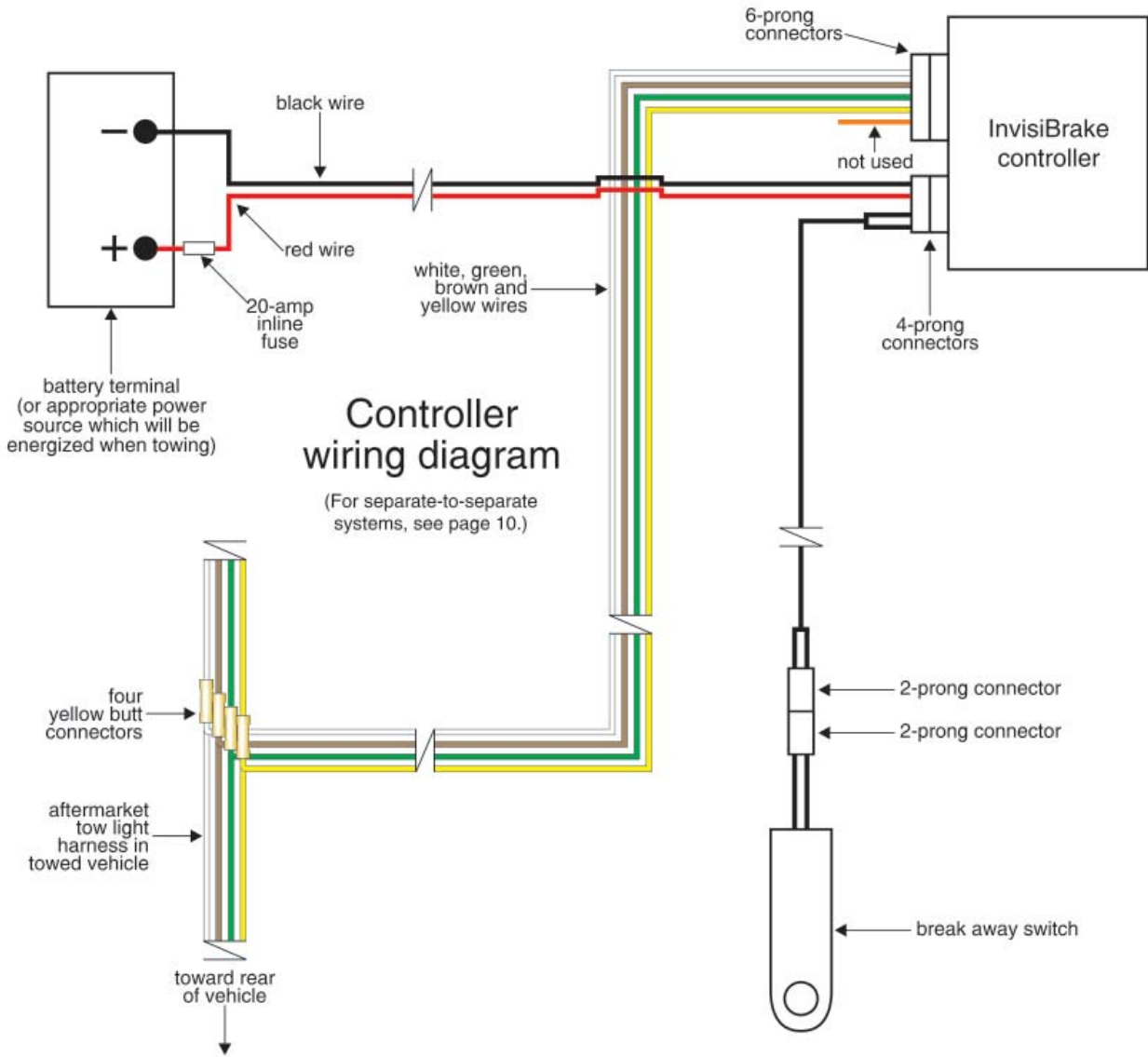

# Warnings and cautions

---

1. The controller, pulley, cable anchor bracket, cable housing clamps and the air cylinder are attached with self-tapping screws. Before attaching these parts, make certain that the screws will not damage any components or electronics on the other side.

## **CAUTION**

**Failure to follow these instructions may cause non-warranty damage to the vehicle.**

2. Route all wiring to avoid the possibility of a short circuit or other damage to the vehicle.

## **WARNING**

**Route all wiring to avoid moving parts, sharp edges, the fuel lines or hot components such as the engine or exhaust system.**

**Use the included wire ties to secure the wiring**

**out of the way.**

**Wiring exposed by moving parts, sharp edges or hot components may cause a short circuit, which can result in damage to the vehicle's electrical system as well as other, consequential damage.**

**Wiring which is attached in close proximity to the fuel lines may ignite the fuel.**

**Failure to follow these instructions may cause property damage, personal injury or even death.**

## **WARNING**

**All parts in the interior of the vehicle must be attached so that they will not present an obstruction or hazard to the driver of the vehicle or interfere with the operation of the vehicle.**

**Failure to follow these instructions may cause a loss of vehicular control, resulting in property damage, personal injury or even death.**

# Plan the installation

*Note: the mounting locations of the controller, pulley and air cylinder are dependent on each other – where you chose to attach one affects the mounting locations of the other two. Before attaching any of these components, plan where they will all be attached, by following the steps below.*

*Note: some newer vehicles may require additional equipment. Check the ROADMASTER web site – [www.roadmasterinc.com](http://www.roadmasterinc.com) – for vehicle-specific information. Select ‘Vehicle-Specific Info,’ enter the vehicle make, model and year, then select ‘Braking Systems.’*

## Choose a mounting location for the controller

The ideal location for the controller (page one) is under the driver’s or passenger’s seat. However, it can be mounted anywhere in the interior of the vehicle – under the rear seats, in the trunk or behind panels.

The controller can be mounted horizontally, vertically or upside down.

Choose a mounting location that meets the following conditions –

- The brake pressure adjustment knob (page one) must be accessible to the installer.
- If you mount the controller under one of the seats, test to make certain that the controller will not interfere with the movement of the seat or affect any adjust-

ments to the seat.

- The controller will be attached with two of the 3/8" self-tapping screws. The underlying material must be of sufficient strength to hold the controller in place.

- An electrical harness will be routed from the controller to the vehicle’s battery (or if the battery is inaccessible, to an appropriate power source which will be energized when towing). Since the harness is 15 feet long, the mounting location should be within 15 feet of the battery (or power source).

Position the controller at the mounting location you have chosen, but **do not attach it** – it will be easier to connect the wiring, air line and vacuum line with the controller loose.

## Choose a mounting location for the pulley and brake pedal clamp

Position the pulley and both sections of the brake pedal clamp as shown in Figure 1, so that they are directly in line with each other.

1. The two sections of the brake pedal clamp can be attached in the following ways...

- With the slot in the L-shaped clamp (Figure 2) on either side of the brake pedal arm.
- With the slot rotated toward the firewall or away

*continued on next page*

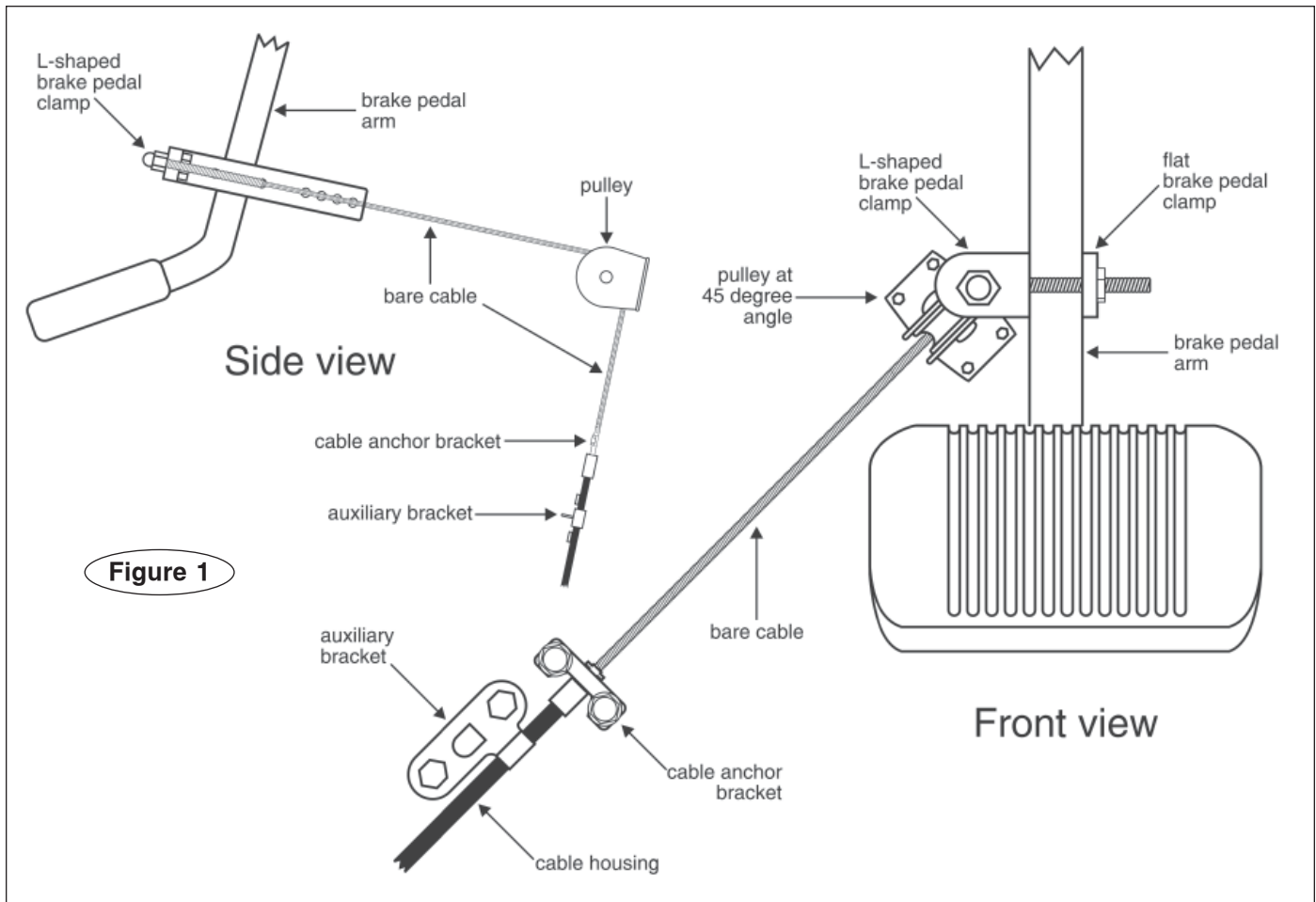

**Choose a mounting location for the pulley and brake pedal clamp**

*continued from preceding page*  
from it (Figure 2).

- The clamp is attached with bolts through two of the five pre-drilled holes (Figure 2). You can move the clamp forward or backward on the brake pedal arm by using different attachment holes.

- If more clearance is necessary, you can trim a portion of the clamp, once you have decided which two of the pre-drilled holes you will use to attach the clamp.

*Note: position the clamp as far down the brake pedal arm as possible – the farther down the clamp is mounted, the more efficiently the supplemental braking system will operate.*

2. The adjuster sleeve (Figure 3) will be attached to the slot in the L-shaped clamp. With this in mind, determine which side of the brake pedal arm will position the ball at the end of the cable directly in line with the pulley.

3. Based on where the cable will be anchored, determine if the clamp should be rotated with the slot toward the firewall or away from it. See “Option One” and “Option Two” in Figure 2.

**⚠ WARNING**

**Make certain that no part of the bracket interferes with the full and complete movement of the brake pedal arm. Property damage, personal injury or even death may occur if the brake pedal cannot be operated at its full range.**

**⚠ WARNING**

**If the vehicle is equipped with brake pedal pre-sets, install the cable and brake pedal clamp assembly with the brake pedal as close to the driver’s**

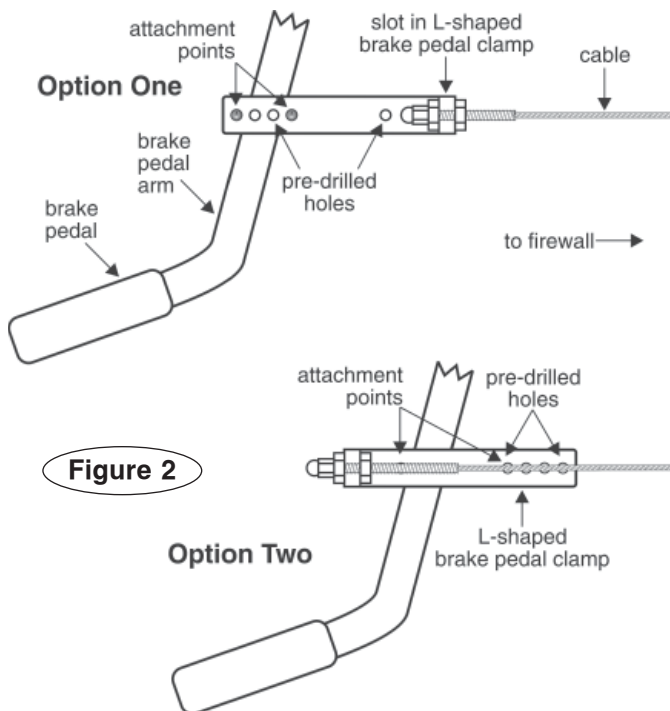

**Figure 2**

**seat as possible. Make certain that the brake pedal is at that position when towing.**

**As an option, the brake pedal may be moved to the desired position and disabled. Do not rely on a mental note to never move the brake pedal.**

**Failure to follow these instructions may cause unintended braking and eventual brake failure, which may result in property damage, personal injury or even death.**

4. Look for a mounting location for the pulley on the firewall that meets the following conditions:

- The pulley (Figure 1) must be positioned directly in line with the L-shaped brake pedal clamp so that the cable aligns directly to the center of the pulley wheel (Figure 4).

*Note: depending on which side of the brake pedal arm you have chosen to attach the L-shaped clamp, it may be necessary to adjust the position of the pulley slightly to the left or right.*

*Note: if the pulley can be attached at a 45 degree angle to the firewall (as shown in Figure 1), it will be much easier to route the cable housing.*

- The pulley must be attached directly to metal – if the mounting location is carpeted, a section large enough for the pulley must be removed.

- The pulley will be attached with four 5/16" self-tapping screws. Make certain that the screws will not damage any components or electronics on the other side of the firewall.

**Do not attach the pulley or brake pedal clamp now.**

*continued on next page*

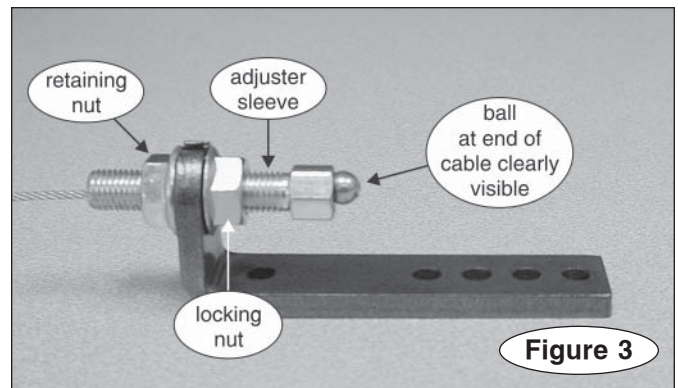

**Figure 3**

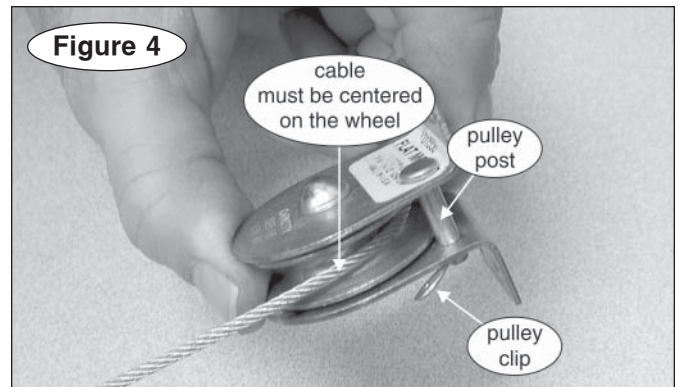

**Figure 4**

## Plan the installation

*continued from preceding page*

### Choose a mounting location for the cable anchor bracket and cable assembly

Based on where you will attach the pulley and brake pedal clamp, find the mounting location for the cable anchor bracket (Figure 1). This point must...

- ...position the cable directly in line with the pulley.
- ...take up all of the slack in the cable without depressing the brake pedal.

*Note: if the section of bare cable (Figure 1) is too long for the mounting point you have chosen for the cable anchor bracket, you can wrap the cable around the pulley wheel **once** – this will take up 3.1 inches of slack. Remove the pulley clip and post (Figure 4), wrap the cable, then reattach the post and clip.*

### CAUTION

**Do not wrap the cable more than once or the braking system may fail, causing severe tire and brake damage.**

- ...allow the cable housing and air cylinder to be out of the way and hidden. A typical route is along the driver's side kick panel and underneath the door trim, paneling or carpeting – try to position the air cylinder under the driver's seat. However, the cylinder can be located under the passenger's seat, the center console or the dashboard. Or, depending on the interior design of the vehicle, there may be a more suitable location.

Make certain that the route you choose, as well as the mounting location for the cable anchor bracket, will cause no more than a three-inch, 90-degree bend. Refer to Figure 5.

### CAUTION

**Do not bend the cable housing further than a**

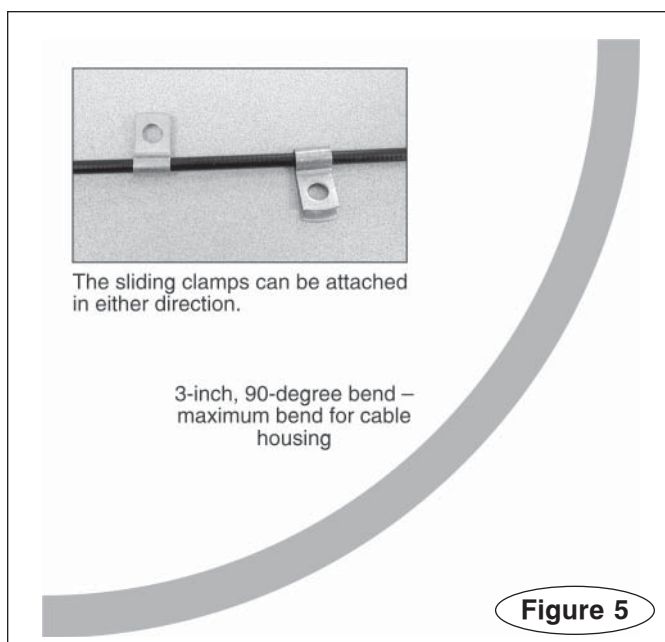

**three-inch, 90-degree bend. Otherwise, InvisiBrake will not release braking pressure after it is activated, which will cause significant non-warranty damage to the towed vehicle's brakes and tires. Other consequential, non-warranty damage may also occur.**

*Note: the auxiliary bracket (Figure 1) can be used to provide additional support. However, it is not necessary in most applications.*

# Begin the installation – attach the brake pedal clamp; attach the pulley; attach the cable anchor bracket

*Note: do not attach any component until you have chosen mounting locations for the controller, pulley and air cylinder – see “Plan the installation,” beginning on page four.*

## Attach the brake pedal clamp

1. Now that you know where all the cable components go, position the two sections of the brake pedal clamp opposite each other. Using the two attachment points (Figure 2) closest to the brake pedal arm, attach the clamp with the two 10-24 x 1½" Allen head bolts and 10-24 Nylock nuts. Finger-tighten the nuts only; you may have to adjust the clamp later.

2. Attach the adjuster sleeve to the brake pedal clamp – completely unthread the retaining nut (Figure 3) and insert the adjuster sleeve through the hole in the L-shaped bracket.

Finger-tighten both nuts so that the adjuster sleeve is roughly centered on the hole in the L-shaped bracket; you will adjust the cable later.

## Attach the pulley

1. Route the bare cable over the pulley and position the pulley at the mounting location you have chosen. Make certain that the side of the pulley with the post (Figure 4) is facing away from the cable anchor bracket.

Make certain that the cable is in a straight line from the brake pedal clamp to the pulley. If it is not, you can...

- ...rotate the pulley, and/or
- ...move the pulley to a different location, and/or
- ...unfasten the brake pedal clamp and move it up or down the brake pedal arm, and/or
- ...attach the brake pedal clamp in a different way.

2. With four of the 5/16" self-tapping screws, attach the pulley.

3. With a 5/32" Allen wrench and an adjustable wrench, tighten the two nuts at the brake pedal clamp to secure the clamp in place. Make certain that the cable is aligned directly to the pulley (Figure 6).

## **WARNING**

**Make certain that no part of the bracket interferes with the full and complete movement of the brake pedal arm. Property damage, personal injury or even death may occur if the brake pedal cannot be operated at its full range.**

## Attach the cable anchor bracket

1. Position the cable anchor bracket at the mounting location you chose earlier. Check to make certain that the cable is in a straight line to the pulley (Figure 7) and that there is no slack in the cable. Also check to make certain there are no sharp bends near the cable

anchor bracket or the auxiliary bracket (Figure 8).

## CAUTION

**Do not allow sharp bends near the cable anchor bracket or auxiliary bracket. Tight bends will create internal friction between the cable and housing, reducing the efficiency of the braking system, and may cause non-warranty damage.**

2. Move the cable anchor bracket forward or backward until the ball at the end of the cable is clearly visible, as shown in Figure 6. This will allow 1/4" of free play in the cable.

3. With two of the 3/8" self-tapping screws, attach the cable anchor bracket. Use two of the same screws to attach the auxiliary bracket, if desired.

4. Check the towed vehicle's brake lights to make certain that attaching the cable anchor bracket has not caused the brakes to be applied. If they have been, readjust the brake pedal clamp or the adjuster sleeve (see the next section).

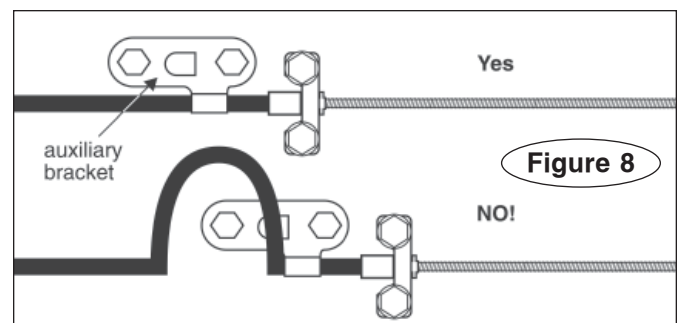
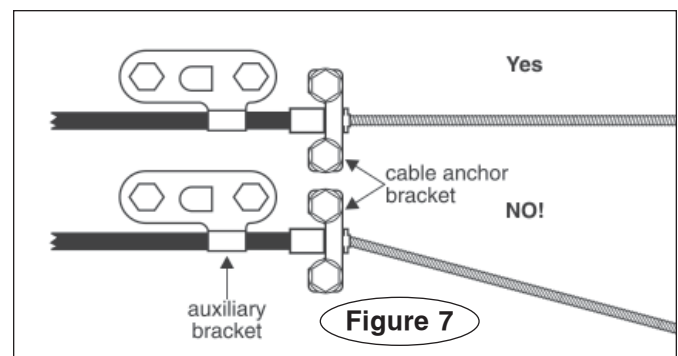
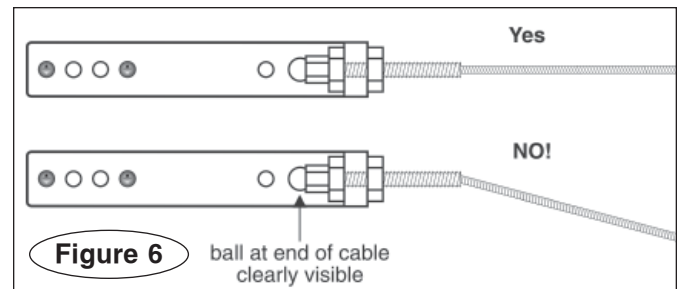

## Adjust the cable for 1/4" of free play

1. A 1/4" of free play is necessary to ensure that the towed vehicle's brakes will not be applied unless the supplemental braking system is activated.

If you do not have 1/4" of free play, adjust the cable by moving the retaining nut and locking nut forward or backward on the adjuster sleeve. This will remove or gain up to 1/2" of slack in the cable.

2. When the ball at the end of the cable is clearly visible (Figure 3), tighten the nuts with two 1/2" wrenches.

3. If you are unable to adjust the cable sufficiently,

you must reposition either the brake pedal clamp and/or the cable anchor bracket.

### CAUTION

Adjust the cable to allow 1/4" of free play, as directed. Otherwise, the towed vehicle's brakes may be applied continuously, which will cause severe tire and brake system damage. Other consequential, non-warranty damage may also occur.

## Route the cable housing and attach the air line

1. Route the cable as planned and attach the air cylinder with the band clamp using a 3/8" self-tapping screw, as shown in Figure 9.

2. If necessary, use one of the sliding clamps (Figure 5) to secure the cable housing in place.

3. Attach the 1/8" air line to the air cylinder – press one end of the line into the port on the air cylinder (Figure 9) until it bottoms out. Route the air line to the controller and, if necessary, trim the line to length – make a smooth, straight cut – then press the other end of the line into the port on the controller (Figure 9) until it bottoms out.

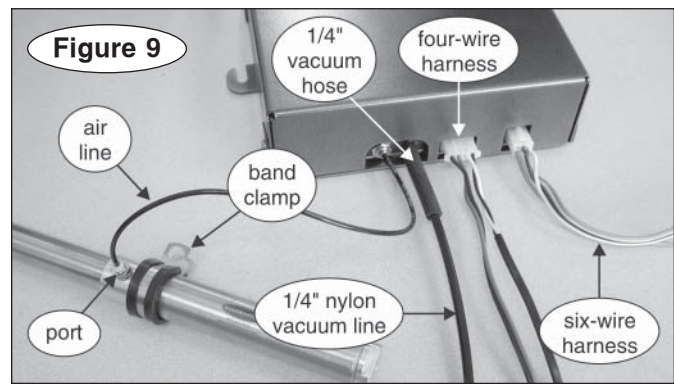

## Attach the vacuum line

*Note: the vacuum line is used on vehicles with vacuum-assisted power brakes. If the vehicle has a full-time ("active") power braking system it will not have a power brake booster (Figure 10). Accordingly, there is no need to install any of the components in this section. Leave the vacuum port as is and proceed to the next section – "Install the break away system; attach the power and ground wires."*

1. Use a section of 1/4" rubber vacuum hose to attach the 15-foot section of 1/4" nylon vacuum line to the controller, as shown in Figure 9.

*Note: a hose clamp is not required for this connection.*

2. Seal the open end of the nylon line with tape. Then route the vacuum line from the controller to the firewall. Choose a route that will conceal the vacuum line.

3. Look for a pre-existing hole with a rubber grommet in the firewall and route the nylon vacuum line through it.

If there is no pre-existing hole, drill a 1/2" hole through the firewall. **Before drilling, make certain you will not damage any components on the other side.**

4. Route the vacuum line through the engine compartment and to the power brake booster (Figure 10).

Avoid moving parts, sharp edges or hot components such as the engine or exhaust system. Do not kink the vacuum line, or bend it to the extent that it crimps or creases.

### ⚠ WARNING

**Do not position the vacuum line close to any heat source. The heat will soften the nylon, which will cause the vacuum line to rupture. If the vacuum line is ruptured, the vehicle's brakes (as well as the supplemental braking system) will not function properly.**

**A loss of vehicular control may result if the**

*continued on next page*

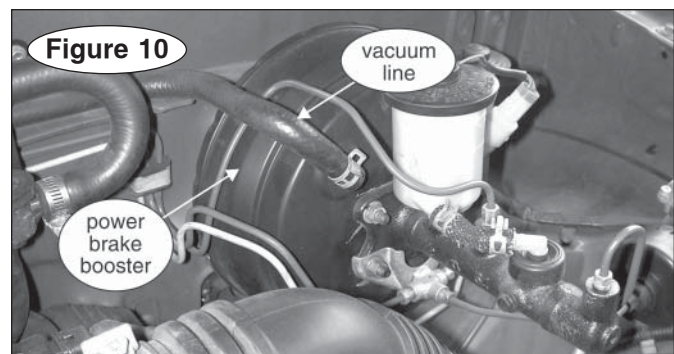

## Attach the vacuum line

*continued from preceding page*

**towed vehicle's brakes do not function properly, which may cause property damage, personal injury or even death.**

### CAUTION

Do not kink the vacuum line, or bend it to the extent that it crimps or creases – vacuum pressure will be substantially reduced, or blocked entirely, at the kink in the line. If vacuum pressure is reduced, InvisiBrake will not function properly.

5. Locate the vacuum line coming out of the power brake booster and cut the line in two places.

### ⚠ WARNING

**Do not drive the vehicle until this installation is complete – once the vacuum line is cut, the vehicle's power brakes will not function. Considerable force will be required to apply the brakes and braking distance will be subsequently lengthened, which may cause property damage, personal injury or even death.**

6. Insert the check valve and tee as shown in Figure 11.

*Note: two sizes of vacuum line tees are provided for varying applications.*

Insert the check valve between the engine and the tee. Position the check valve so that the barbed

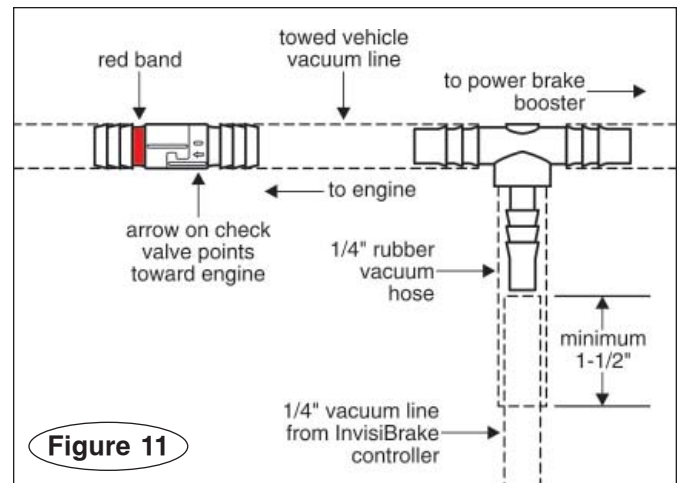

fitting with the red band (Figure 11) is closest to the engine, and that the arrow on the check valve (Figure 11) is pointing toward the engine.

### CAUTION

The supplemental braking system will not function if the check valve is inserted with the arrow pointing away from the engine.

7. Press the 1/4" rubber vacuum hose over the bottom of the tee, as shown in Figure 11.

8. Remove the tape and, if necessary, cut the 1/4" vacuum line from the controller to length. Insert the open end into the 1/4" rubber vacuum hose (Figure 11).

9. Make certain that all connections are secure.

## Check the existing wiring

In order for InvisiBrake to function properly, the lighting systems on both vehicles must also function properly.

Before proceeding with the installation...

1. Check the proper function of the brake, turn signal and running lights on the towed vehicle.

2. Independently check the proper function of the brake, turn signal and running lights on the motorhome.

3. Position the vehicle behind the motorhome and connect the tow lighting electrical cord between the two vehicles.

**Do not connect the tow bar** – it may act as a false ground.

4. Use the motorhome to activate the towed vehicle's brake lights, turn signals and running lights. If the towed vehicle's lights appear dim the cause is likely a poor ground in the motorhome or towed vehicle.

## Install the break away system; attach the power and ground wires

1. Attach the four-wire harness (Figure 12) to the corresponding connector on the InvisiBrake controller. Route the other end through the hole in the firewall. Use the same route as the 1/4" vacuum line, if that is convenient.

2. Using the 1" bolt and lock nut (Figure 12), mount the break away switch (Figure 12) at the front of the vehicle. Choose an area you can easily reach, near the center of the vehicle, with a surface of sufficient strength

to hold the switch firmly in place, so that the break away pin (Figure 12) will pull freely from the switch.

Mount the switch in a horizontal position, with the break away pin facing the motorhome.

Make certain that the break away pin can be pulled freely away from the towed vehicle, without any obstructions.

*continued on next page*

**Install the break away system;  
attach the power and ground wires**  
*continued from preceding page*

**⚠ WARNING**

**Do not attach the break away switch to the tow bar or the tow bar bracket. If the tow bar or bracket fails, the break away switch will separate with it, preventing the break away system from activating. If the towed vehicle separates, the brakes will not be applied, which may cause property damage, personal injury or even death.**

3. Route the bundled pair of black wires to the front of the vehicle and plug them into the break away

switch.

4. Route the bonded pair of black and red wires to the towed vehicle's battery (or if the battery is inaccessible, to an appropriate power source which will be energized when towing). Using the two 3/8" ring terminals, connect the wires as shown on page two in the controller wiring diagram.

Make certain to install the 20-amp fuse.

*Note: if the vehicle owner's manual indicates that the battery must be disconnected for towing, the wires must be routed directly to the battery or InvisiBrake will not work.*

*Note: an Automatic Battery Disconnect (part number 765) and stop light switch kits for most popular towed vehicles are available through ROADMASTER.*

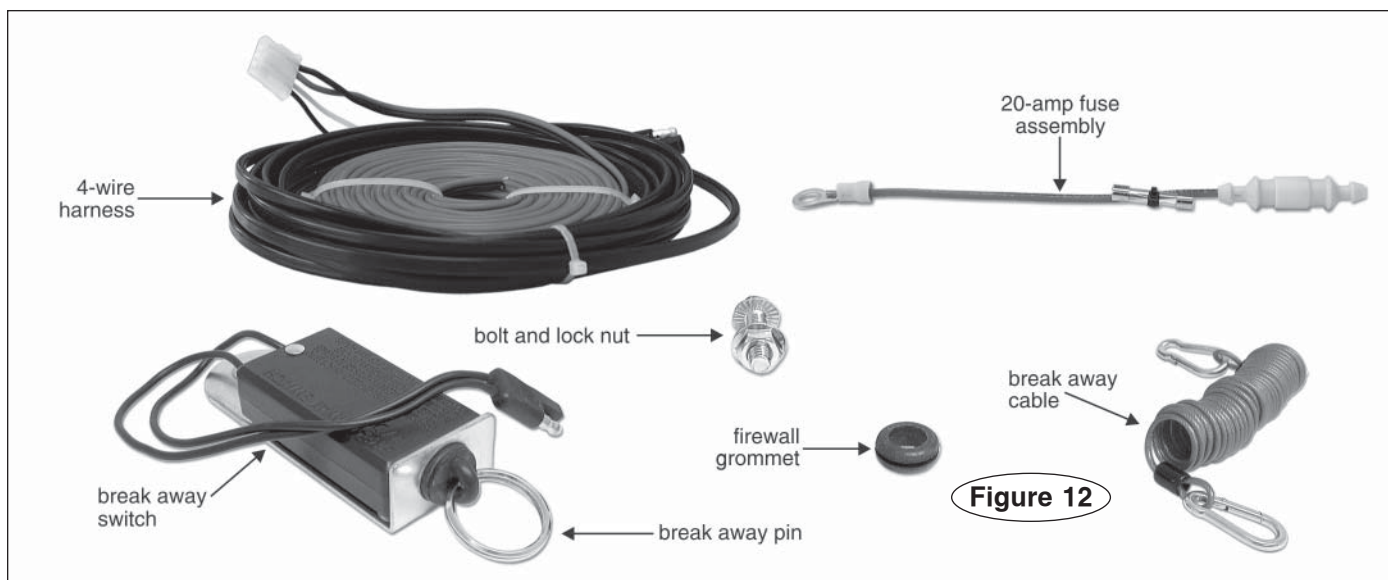

**Figure 12**

## Attach the four-wire flat harness; attach the controller

*Note: the following wiring instructions are based on a typical connection from the motorhome. For other wiring applications, contact ROADMASTER.*

**CAUTION**

**If the towed vehicle's turn signals, taillights and brake lights have been wired for towing, the connection you are about to make to the aftermarket tow light harness must be upstream of the wiring diodes.**

**If it is not, InvisiBrake will not function properly. Severe damage to the towed vehicle's tires and brakes, as well as other consequential, non-warranty damage, may also occur.**

**(If a bulb and socket wiring system has been used, diodes are not necessary.)**

1. Attach the four-wire flat harness (page two) to the corresponding connector on the controller.
2. Route the harness to the vehicle's aftermarket

tow light harness.

3. Find a convenient point to attach the wires to the aftermarket tow light harness.

With a test light, identify the ground, right turn, left turn and taillight wires in the tow light harness. Typically, the wires are color-coded as follows:

white .....	ground
green .....	right turn and brake
yellow .....	left turn and brake
brown .....	taillights
any color .....	brake

**CAUTION**

**Color coding is not standard with all manufacturers. Use the color codes listed above for initial reference only; confirm the function of each wire with a test light.**

**The vehicle's lighting system may not function, or function improperly, if the wires are not connect-**

*continued on next page*

**Attach the four-wire flat harness;  
attach the controller**

*continued from preceding page*

**ed correctly. Cross-wiring may also cause a short circuit, a blown fuse or other electrical damage.**

4. Refer to Figure 13 or 14 to attach the six-wire harness.
5. All connections have now been made to the con-

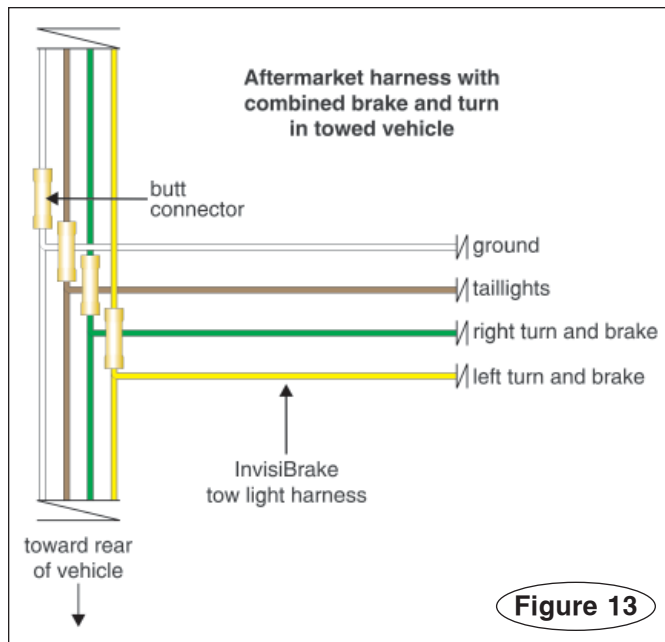

troller. With two of the 3/8" self-tapping screws, attach the controller at the mounting location you chose earlier.

6. You will test and adjust for proper braking pressure in a later step. So leave the brake pressure adjustment knob on the controller (page one) accessible – do not reinstall any trim panels that would prevent adjusting the brake pressure.

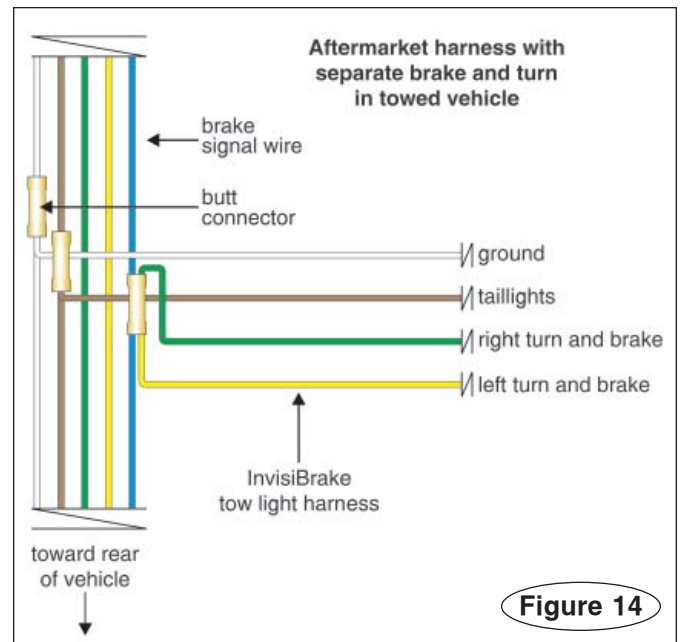

## Install the monitor system

### Install the monitor harness in the towed vehicle

1. Follow all of the steps in the owner's manual to prepare the vehicle for towing (for example: neutral; ignition switch position; pull fuses; etc.).

2. Apply the brakes and check to see if the brake lights illuminate. If they do not, an optional stop light switch kit must be installed – visit [www.roadmasterinc.com](http://www.roadmasterinc.com).

*Note: check the owner's manual to see if the vehicle has an "automatic shut down" feature. If so, an optional stop light switch kit must be installed, as the brake light switch will stop working at some point during towing.*

3. Choose a mounting point at the front of the vehicle, near the electrical socket, for the end of the 15-foot harness with a female bullet connector.

Attach the connector with one or more wire ties; allow enough slack so that a matching connector can be plugged into and out of it.

4. Route the other end of the harness through the engine compartment and through the hole in the firewall. Use the same route as the break away wiring harness, if that is convenient.

5. Locate the towed vehicle's brake light switch. With a multi-meter, find the "cold" side of the switch. (The cold side of the switch does not register voltage unless the brakes are applied.)

Remove the vehicle's brake light fuse.

### CAUTION

**Failure to remove the brake light fuse may cause the vehicle's theft deterrent system, or other electrical system indicators, to be activated if the brake pedal is depressed during the installation. This may require non-warranty repair to the vehicle.**

6. Cut the brake light wire, a few inches downstream from the cold side of the brake light switch.

*Note: if a Brake-Lite Relay is installed, the connection must be between the Brake-Lite Relay and the brake light switch.*

7. If necessary, trim the monitor wiring harness. Attach the monitor wire and one end of the wire from the cold side of the brake light switch to one side of a yellow butt connector.

Attach the other end of the wire from the brake light switch to the other end of the yellow butt connector.

8. Reinstall the brake light fuse.

### Seal the firewall

1. If you had to drill a hole through the towed vehicle
- continued on next page*

## Install the monitor system

*continued from preceding page*

cle's firewall, cut the grommet (Figure 12) on one side, and slide it over the nylon vacuum line, the monitor harness and all of the electrical wiring from the controller.

Fit the grommet into the hole in the firewall.

2. Completely seal the grommet with a silicone sealant.

*Note: failure to seal the grommet completely may allow engine fumes and water into the passenger compartment.*

3. Reattach the door trim, paneling or carpeting over the vacuum line, cable housing and the electrical wiring from the controller.

## Install the monitor system in the motorhome

*Note: some motorhomes are manufactured with auxiliary wires pre-strung from the rear of the motorhome to the dashboard – if the motorhome has such a wire, use it instead of the 50-foot wire included in the kit, which will save time.*

*Refer to the motorhome owner's manual or call the dealership.*

1. If there is no pre-existing wire, attach the end of the 50-foot length of black wire with the female bullet connector to the back of the motorhome, near the electrical socket.

Attach the connector with one or more wire ties. Allow enough slack so that a matching connector can be plugged into and out of it.

2. Route the other end of the wire from the back of the motorhome to the underside of the dashboard.

3. Choose an area on the dashboard to mount the LED, where the LED can be easily seen by the driver.

4. Drill a 5/16" hole through the dashboard at the point you have chosen. **Before drilling, confirm that the**

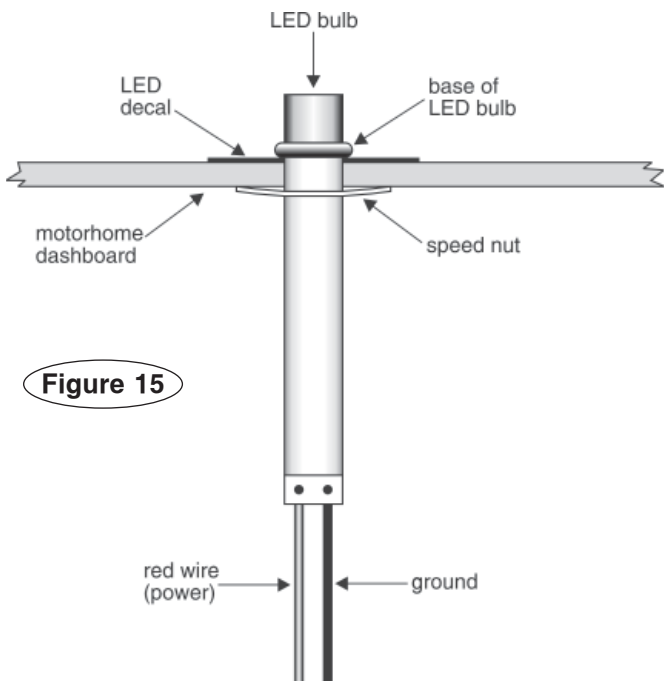

**location of the LED is approved by the owner, and make certain you will not damage the dashboard or any components on the other side.**

5. Center the LED decal (Figure 15) over the hole, and press it down. Or, you may choose to omit the decal, depending on your preferences.

6. From the top of the dashboard, slide the LED through the hole, wires first, until the base of the bulb (Figure 15) is flush to the top of the dash.

7. From the underside of the dash, fit both of the wires through the speed nut (Figure 15). Then push the speed nut up, against the dash, to secure the LED.

8. With one or more wire ties, attach the audio signal circuit board (Figure 16) to the underside of the dash, as close to the LED as possible.

9. Connect the monitor LED, audio signal circuit board and the black wire from the rear of the motorhome as shown in Figure 16.

## Connect the monitor wire patch cord

1. Attach the male bullet connectors on the monitor wire patch cord (page one) to the matching connectors on the motorhome and towed vehicle.

*Note: if there is an open terminal available on both electrical sockets, you can use the existing electrical cord to connect the monitor wiring between the two vehicles. This method eliminates the monitor wire patch cord.*

2. The installation is complete. Before operating InvisiBrake you must test all functions, as described in the next section.

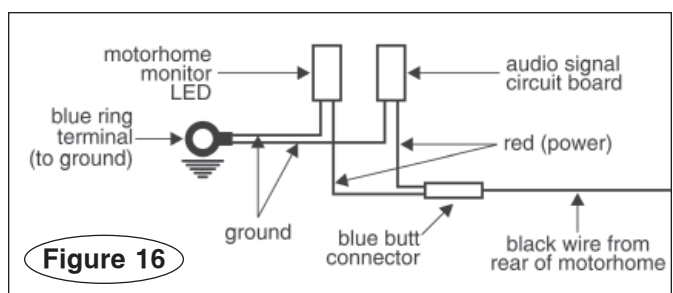

# Test the system; evaluate the brake pressure setting

## Test drive the motorhome

Drive the motorhome for a short distance, making a few stops. Get a good feel for the motorhome's braking ability. Later, you will compare how the motorhome brakes by itself with how it brakes with the towed vehicle and InvisiBrake.

## Connect the vehicles for towing

1. According to the manufacturer, make all adjustments necessary to prepare the vehicle for towing. Refer to the owner's manual or call the dealership for vehicle-specific information.

2. Make all connections between the towed vehicle and the motorhome, including tow bar, wiring kits, monitor wire patch cord, etc.

## Test the system

The following tests can be performed with the motorhome and towed vehicle stationary.

1. **Confirm braking** – with the motorhome engine running, depress and hold the motorhome brake pedal down. The towed vehicle's brake pedal will be depressed. Then, release the motorhome brake pedal. At the towed vehicle, the brake pedal will retract.

2. **Confirm that the motorhome monitor is functioning** – the LED will illuminate after the motorhome's brake pedal is depressed and stop illuminating when the brake pedal is released.

3. **Confirm the proper operation of the extended braking protection mode** – depress and hold the motorhome's brake pedal down. The towed vehicle's brake pedal will be depressed. After approximately 15 seconds, the brake pedal will retract, even though the motorhome brake pedal is still depressed.

4. **Confirm the proper operation of the audio alert** – in the **towed vehicle**, depress and hold the brake pedal down. After approximately 20 seconds, the audio alert will sound in the motorhome. (To cancel the audio alert, release the towed vehicle's brake pedal.)

## WARNING

If InvisiBrake fails any of the above tests, you must refer to the "Troubleshooting" section in the owner's manual and repair the fault before towing.

Failure to follow these instructions may cause property damage, personal injury or even death.

Results of system test –

Passed     Failed

Test performed by: \_\_\_\_\_ Date: \_\_\_\_\_

**Return this document to the owner of the vehicle.**

## Evaluate the braking pressure

InvisiBrake's braking pressure has been pre-set at the factory at a level appropriate for most towed ve-

hicles. While there may be no adjustment necessary, it's important to evaluate the pressure for each specific combination of vehicles.

## For vehicles with full-time ('active') power braking systems...

**IMPORTANT** – if the towed vehicle is a hybrid, Hummer H3 or any other vehicle with full-time ('active') power brakes, you **must** lower the brake pressure setting to 20 psi before proceeding with the test – First, follow the instructions under "If necessary, change the brake pressure setting" (on the next page) to lower the setting. Then go to "Test-drive the motorhome and towed vehicle" (below).

## CAUTION

**If the towed vehicle has full-time ('active') power brakes, the brake pressure setting must be lowered before the test drive. Otherwise, InvisiBrake will apply excessive force to the towed vehicle's brakes, which will 'flat-spot' the tires, damage the braking system or cause other non-warranty damage.**

## Test-drive the motorhome and towed vehicle

1. Drive the motorhome and towed vehicle for a short distance, making six to eight stops.

The degree to which the brake pressure setting will affect the motorhome will vary, depending on the size and weight of the motorhome in comparison to the size and weight of the towed vehicle –

- **Brake pressure set too high** – a sharp pull at the motorhome may indicate that the brake pressure is set too high – in this case, you may choose to lower the setting until the towed vehicle brakes with less force. See "If necessary, change the brake pressure setting," below.

## WARNING

It is possible to lower the brake pressure setting to the point that it negates the benefit of the supplemental braking system and break away. Insufficient brake pressure will lengthen stopping distance.

Failure to follow these instructions may cause property damage, personal injury or even death.

- **Brake pressure set too low** – if the combination of vehicles takes longer to stop than the motorhome alone, you may choose to raise the setting. See "If necessary, change the brake pressure setting," below.

## WARNING

**If brake pressure is set too high, InvisiBrake will**

*continued on next page*

**Test the system;  
evaluate the brake pressure setting**

*continued from preceding page*

**apply excessive force to the towed vehicle's brake pedal, which will cause tire and brake system damage, as well as other consequential, non-warranty damage.**

**Failure to follow these instructions may cause property damage, personal injury or even death.**

**If necessary,  
change the brake pressure setting**

1. Pull the break away pin (Figure 12). The pressure gauge on the controller (page one) will display the current braking pressure.

**CAUTION**

**Reinsert the brake away pin within five minutes, or premature compressor failure may result.**

2. Pull out on the brake pressure adjustment knob (page one) to unlock it. Turn the knob clockwise to increase the braking pressure or counterclockwise to decrease the braking pressure.

3. Adjust the pressure by no more than 10 psi.

4. Push the brake pressure adjustment knob in to lock it in place. Reinsert the break away pin.

5. Repeat the test drive and, if necessary, adjust again until you are satisfied with the brake pressure setting.

 **WARNING**

**Every time you adjust the brake pressure, you must test drive the motorhome and towed vehicle. After repetitive braking, check for excessive heat near the center of the towed vehicle's wheels – this indicates that the brakes are overheating and that the brake pressure is set too high.**

**You must lower the braking pressure and retest until the brakes are not excessively hot.**

**Failure to follow these instructions may cause brake failure, resulting in property damage, personal injury or even death.**

**Finish the installation**

The installation and tests are complete. If necessary, replace any trim panels that were removed to install the controller.



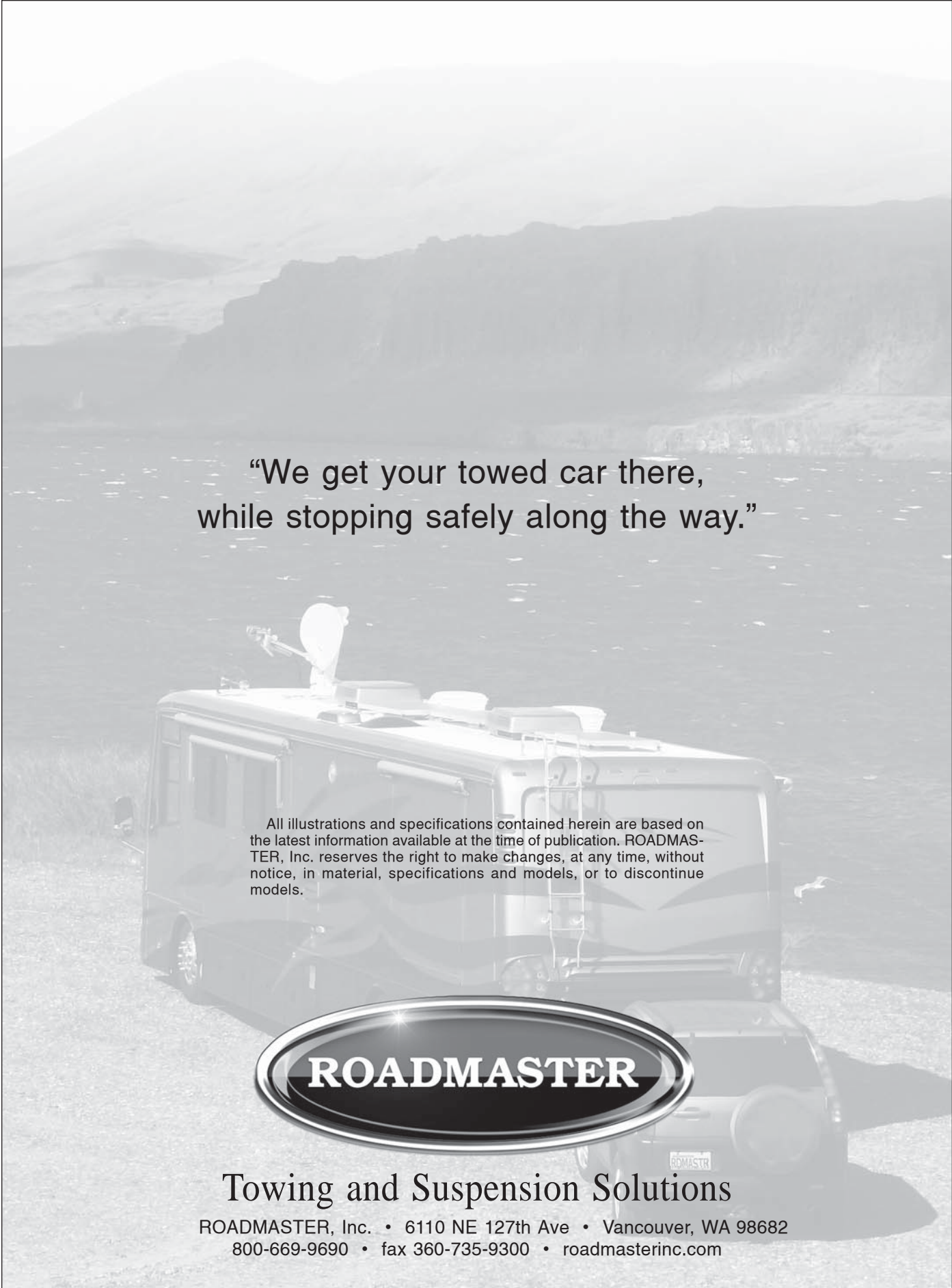

**“We get your towed car there,  
while stopping safely along the way.”**

All illustrations and specifications contained herein are based on the latest information available at the time of publication. ROADMASTER, Inc. reserves the right to make changes, at any time, without notice, in material, specifications and models, or to discontinue models.



## **Towing and Suspension Solutions**

ROADMASTER, Inc. • 6110 NE 127th Ave • Vancouver, WA 98682  
800-669-9690 • fax 360-735-9300 • [roadmasterinc.com](http://roadmasterinc.com)