



# *Owner's Manual*

***Entire contents of manual must be read by owner***

**FREE!**  
NEW EXTENDED  
WARRANTY  
AVAILABLE -  
30-DAY DEADLINE



Towing and Suspension Solutions

ROADMASTER, Inc. • 6110 NE 127th Ave. • Vancouver, WA 98682  
800-669-9690 • Fax 360-735-9300 • [roadmasterinc.com](http://roadmasterinc.com)

© 2011 ROADMASTER, Inc. All rights reserved. 853326-08 12-11

# WELCOME TO THE ROADMASTER FAMILY!

This manual has been prepared to acquaint you with the installation, operation, care and maintenance of your tow bar and to provide you with important safety information.

Read your owner's manual cover to cover. Understand how to install and operate your tow bar, and carefully follow the instructions and safety precautions.

Your tow bar has a one-year limited warranty. To qualify for your warranty, register online at [www.roadmasterinc.com/wreg](http://www.roadmasterinc.com/wreg), or fill out and return the enclosed product registration card. **As a bonus, we'll extend your warranty to a total of two years at no additional cost, if we receive your registration (either online or mailed) within 30 days of purchase.**

We thank you for your patronage and greatly appreciate your discerning taste.

## Table of Contents

Safety definitions .....	inside front cover
Safe towing practices .....	1-2
Installer's safety checklist .....	2
Installing the 'quick-disconnect' system.....	3-4
Connecting and disconnecting	
Connecting the tow bar .....	4-5
Disconnecting the tow bar.....	6
Wiring instructions	
Wiring a six-wire system .....	6-7
Wiring a seven-wire system .....	7
Safety cables	
How to use safety cables .....	8
Proper installation of safety cables .....	9
Stay within the 'Safe Zone'.....	10
Care and cleaning .....	10-11
Limited warranty .....	11
Tow bar components .....	back cover

## Save this manual

Save this manual for future reference. It contains important sections relative to safety, use, maintenance, parts replacement and other information. Therefore, make sure this manual is always with you when you're towing. You may download or print a copy of the most current manual at [www.roadmasterinc.com](http://www.roadmasterinc.com) (under 'Support').

### WARNING

**Read all instructions before installing the tow bar or before towing a vehicle. Failure to understand how to properly install or operate the tow bar could result in property damage, personal injury or even death.**



### Your tow bar serial number...

...is located on a label on the inside of the driver's side tow bar arm. You will need this number when you fill out your product registration card.

Write down the serial number in the space below and retain for future reference.

Serial number: \_\_\_\_\_

All illustrations and specifications contained herein are based on the latest information available at the time of publication. ROADMASTER, Inc. reserves the right to make changes, at any time, without notice, in material, specifications and models, or to discontinue models.

## IMPORTANT NOTICE! Safety Definitions

This manual contains information that is very important to know and understand. This information is provided for **safety** and to **prevent equipment problems**. To help recognize this information, observe the following symbols:

### WARNING

**WARNING indicates a potentially hazardous situation which, if not avoided, could result in property damage, serious personal injury or even death.**

### CAUTION

**CAUTION indicates a potentially hazardous situation which, if not avoided, may result in property damage, or minor or moderate personal injury.**

### CAUTION

**CAUTION used without the safety alert symbol indicates a potentially hazardous situation which, if not avoided, may result in property damage.**

### NOTE

*Refers to important information and is placed in italic type. It is recommended that you take special notice of these items.*

# SAFE TOWING PRACTICES

## CAUTION

- **Do not back up the motorhome with the towed vehicle attached.**

Backing up with the towed vehicle attached will cause the towed vehicle to “jackknife,” which will damage the tow bar, the mounting bracket, the receiver hitch, the towed vehicle’s front end, and/or the rear of the motorhome. Backing up with the towed vehicle attached is the primary cause of tow bar damage and will void the warranty.

- **Be sure the vehicle can be towed** before taking it on the road. Some vehicles must be equipped with a transmission lube pump, an axle disconnect, driveline disconnect or free-wheeling hubs before they can be towed. Failure to properly equip the vehicle will cause severe damage to the transmission.

Check the vehicle manufacturer’s instructions for the proper procedure(s) to prepare the vehicle for towing.

- **The tow bar must be within the ‘Safe Zone’** – no more than three inches above or below level. Towing with an out-of-level tow bar will cause significant wear and tear on the tow bar and mounting brackets, and on the towed vehicle’s suspension and frame. (See the section titled “Stay within the ‘Safe Zone’” for further information.)

- **The steering wheel must be unlocked and free to turn when towing.** Failure to do so can cause severe tire and equipment damage. Check the manufacturer’s instructions for the proper towing procedure(s).

- **The towed vehicle and all its contents cannot exceed 6,000 pounds.** The Sterling All Terrain tow bar is rated at a maximum of 6,000 pounds carrying capacity; therefore the towed vehicle and all its contents cannot exceed 6,000 pounds.

In addition, the receiver hitch, the safety cables and all supplementary towing equipment must be rated at no less than the weight of the towed vehicle and all its contents.

- **The tow bar must be secured with lynch pins (or optional padlocks) before towing.** Unless the tow bar is secured to both vehicles with all appropriate pins (or padlocks), the towed vehicle will detach.

- **Inspect the system before towing** – check the mounts, brackets, fasteners, bolts, wiring, the safety cables and all other components each time before towing.

Additionally, check the tow bar bracket every 3,000 miles – inspect for any fractures or cracks in the steel, or any visible damage. Do not tow if the tow bar bracket is damaged.

Additionally, check the torque on all bolts. (To find the torque ratings, refer to the installation instructions for the mounting bracket and the tow bar.)

- **This tow bar is designed for use on paved roads only.** ROADMASTER does not recommend off-road towing, nor does ROADMASTER warrant the tow bar for off-road use.

- **Never tow a vehicle with one of a comparable**

**weight.** The towed vehicle’s weight should never exceed 40 percent of the towing vehicle’s weight.

Towing a vehicle with one of similar weight will cause the towed vehicle to override the towing vehicle, resulting in “jackknifing,” “leapfrogging” or “fishtailing.” Serious damage to both vehicles, as well as the towing system, could result.

- **Do not drill a second hole in the shank of any tow bar or hitch accessory.** If the hole in the shank does not align to the hole in the hitch receiver: 1) purchase a hitch accessory of the appropriate length; or 2) call ROADMASTER technical support.

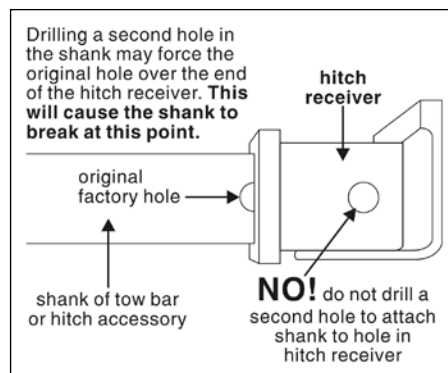

Drilling a second hole will weaken the steel. The shank may break during towing, which will cause the towed vehicle to separate.

- **Always stand to one side and as close to the motorhome as possible when releasing the tow bar locking mechanisms.** Never stand between the adjustable arms, or put any part of your body between the adjustable arms, when releasing the tow bar – always stand to one side. Because the towed vehicle may jerk forward when the locking mechanisms are released, face the towed vehicle and stand as close to the back of the motorhome as possible before releasing the locking mechanisms, to keep from being hit by the towed vehicle.

- **Always use safety cables when towing.** The safety cables, which are provided with the Sterling All Terrain, must connect the towed vehicle to the towing vehicle frame to frame.

If the safety cables are ever replaced, use only 6,000 pound or heavier rated safety cables.

Additionally, check to ensure that the safety cables are the proper length. Refer to the sections titled “How to use safety cables” and “Proper installation of safety cables” for further information.

- **Check the motorhome turning radius.** Some motorhome chassis have such a tight turning radius that you can damage your motorhome, towed vehicle or tow bar while turning too sharply. Before getting on the road with your towed vehicle, you should test your turning radius in an empty parking lot.

With the towed vehicle attached, have someone watch as you slowly turn sharply to see whether you have this potential problem. If you do, note how far you can safely turn the motorhome’s steering wheel and be sure not to turn it further when towing. Damage that results from turning too sharply is not covered by warranty.

- **Never use the tow bar to tow more than one vehicle.** In some states it is legal to have one vehicle towing

*continued on next page*

## Safe towing practices

*continued from preceding page*

more than just one vehicle (for example, a truck which is towing a trailer which is towing a boat). However, when using a tow bar never tow more than one vehicle, or non-warranty damage or injury may result.

- **The tow bar stinger fits motorhome hitch receivers with two-inch inner diameters.** If the motorhome hitch receiver is a larger size, attach a two-inch adaptor sleeve (not supplied) to the hitch receiver.

Damage to the tow bar stinger or other components of the tow bar, abnormal wear patterns on the towed vehicle's tires, as well as other, consequential damage may result if an adaptor sleeve is not used.

- **Keep the tow bar clean and well-lubricated.** As is the case with most precision equipment, frequent cleaning and care results in better performance and longevity. Refer to the section titled "Care and cleaning" for further information.



**WARNING**

**Failure to follow these instructions may cause property damage, personal injury or even death.**

## INSTALLER'S SAFETY CHECKLIST

The following safety checklist is provided to the installer with the instructions for installing the Sterling All Terrain tow bar. It is repeated here for your information.

As a precaution, verify that all safety requirements have been followed before towing the vehicle.

- **Stress to the owner that the tow bar must be within the 'Safe Zone'** – no more than three inches above or below level. Towing with an out-of-level tow bar will cause significant wear and tear on the tow bar and mounting brackets, and on the towed vehicle's suspension and frame. (See the section titled "Stay within the 'Safe Zone'" for further information.)

- **Show the owner how to properly operate the tow bar.** Familiarize yourself with the features of the tow bar. Demonstrate them to the owner, and ask the owner to connect and disconnect the tow bar and other components of the towing system, until the owner is comfortable with its operation.

- **Caution the owner to use a receiver hitch rated higher than the actual weight of the towed vehicle.**

The motorhome receiver hitch must have a minimum capacity of no less than the weight of the towed vehicle and all its contents.

(The Sterling All Terrain tow bar is rated at a maximum of 6,000 pounds carrying capacity; therefore ROADMASTER has used 6,000 pounds as a standard for rating the weight capacity of all supplementary towing equipment, as well as the towed vehicle and all its contents, throughout this manual.)

- **The tow bar must be attached to a bracket which is bolted to the towed vehicle's frame or unibody.** In order to be towed, virtually all vehicles require a tow bar mounting bracket that is connected to the frame, unibody or chassis and extends beyond the bumper.

- **Caution the owner to secure the tow bar with lynch pins (or optional padlocks) before towing.** Unless the

tow bar is secured to both vehicles with all appropriate pins (or padlocks), the towed vehicle will detach.

- **Advise the owner to use 6,000 pound or higher rated safety cables.** Six thousand pound-rated safety cables are provided with the Sterling All Terrain; if the safety cables are ever replaced, use only 6,000 pound or heavier rated safety cables.

- **Read the instructions thoroughly before installing the 'quick-disconnect' ('QD') system and its components.** The tow bar will be attached to the QD system. If the QD system is not properly aligned, centered and positioned on the towed vehicle, the tow bar will not be centered on the towed vehicle, which may cause excessive tire wear and other consequential, non-warranty damage.

- **The installer must be sure that the vehicle is suitable or adaptable for towing.** Some vehicles must be equipped with a transmission lube pump, an axle disconnect, driveline disconnect or free-wheeling hubs before they can be towed. Failure to properly equip the vehicle will cause severe damage to the transmission.

Check the manufacturer's instructions for the proper procedure(s) to prepare the vehicle for towing.

- **The installer must NOT use the tow bar as a ground for welding.** Connecting a ground to the 'A-frame' of the tow bar will cause current to flow through the locking spring, which will detemper the spring and destroy the locking mechanism.

- **Under no circumstances should the tow bar be welded to the vehicle,** nor should any of the pre-punched mounting holes be altered. Any welding or altering of the tow bar will void the owner's warranty.



**WARNING**

**Failure to follow these instructions may cause property damage, personal injury or even death.**

# INSTALLING THE 'QUICK-DISCONNECT' SYSTEM

This ROADMASTER tow bar is equipped with an exclusive "quick-disconnect" (or, "QD") system. Before connecting the tow bar to the vehicle, first install the components of the QD system to the mounting bracket.

*Note: the quick-disconnect system is not used with ROADMASTER 'MS' or 'MX' series mounting brackets. If the towed vehicle has MS or MX brackets, proceed to the next section – "Connecting the tow bar." The quick-disconnect system should be reserved, however, for subsequent vehicles which may not have these brackets.*

1. First, attach the quick-disconnects ("QDs," parts "A" and "B" in Figure 1) to the tow bar mounting brackets. Attach the QDs so that the vertical pin on each is pointing up, as shown in Figure 1.

Attach part "A" on the passenger side and part "B" on the driver's side. Use the supplied  $\frac{1}{2}$ " x  $1\frac{3}{4}$ " bolts, the two safety plates (parts "C"), and the flat washers, lock washers and nuts, as shown in Figure 1.

Both QDs have cable anchors – parts "D" and "E" in Figure 1 – designed for safety cable attachment. Bolt cable anchor "D" to part "A," and cable anchor "E" to part "B," using the supplied  $\frac{1}{2}$ " x 1" bolts and nuts.

Do not tighten any of the bolts – leave them loose for now – they will be tightened later.

## **⚠ WARNING**

**Use all mounting hardware, the safety plates and the cable anchors. If all supplied materials are not used,**

**the quick-disconnects, the quick-disconnect bases or other components may vibrate loose, which may cause property damage, personal injury or even death.**

2. Now, test-fit the crossbar – lower the crossbar (Figure 2) over the quick-disconnects. The vertical pins at the top of both QDs should fit through the top holes at the ends of the crossbar (Figure 2), and the vertical pins at the bottom of the crossbar should fit through

*continued on next page*

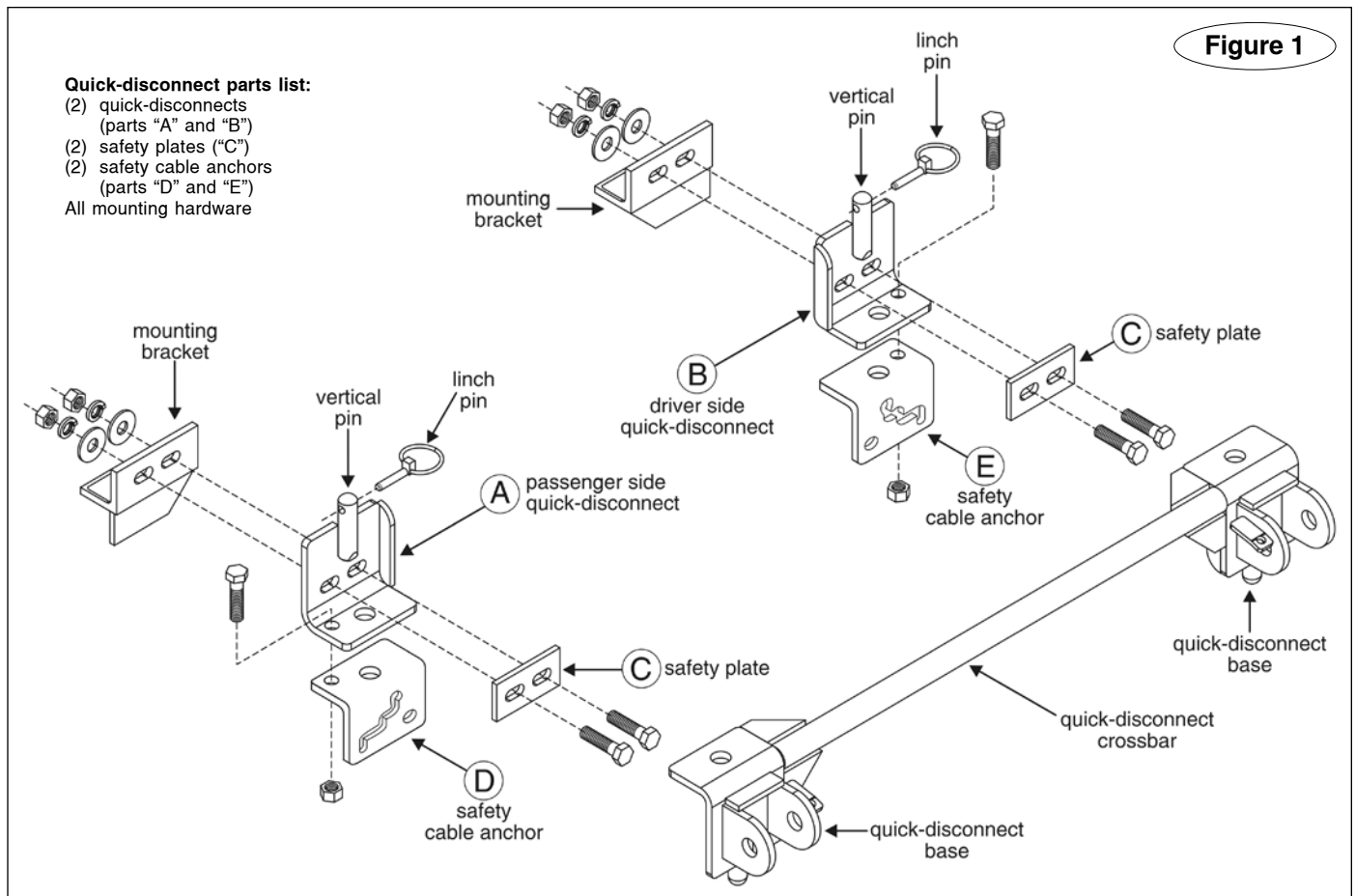
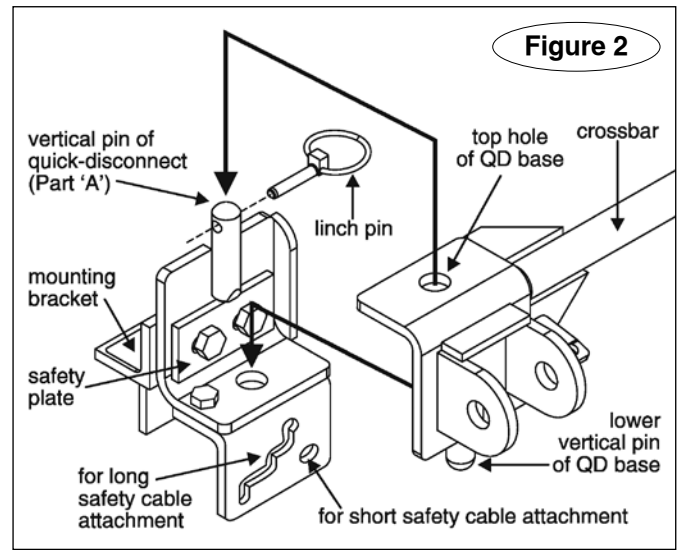

## Installing the 'quick-disconnect' system

*continued from preceding page*

the lower holes on the quick-disconnects (Figure 2).

3. The quick-disconnects must be positioned so that the tow bar is centered on the front of the vehicle.

If necessary, adjust the quick-disconnects by moving them to the left or the right, until the tow bar is centered to the front of the vehicle

### CAUTION

The quick-disconnects must be centered on the mounting brackets. If they are attached too far to the left or the right, the tow bar will not be centered on the towed vehicle, which will cause excessive tire wear and other consequential, non-warranty damage.

4. Once the crossbar slides on and off easily, torque the four bolts to 75 ft./lbs. Again, test-fit the crossbar over the QDs, to verify that the crossbar slides on and off easily. If it does not, adjust the QDs again.

5. Insert the linch pins (Figure 3) through the upper holes in the vertical pins on both QDs.

All linch pins must be locked. The rings are spring-loaded – they must be snapped over the pins, as shown in Figure 3, with the curved side of the linch pin touching the ring, in order to keep the QD bases secure.

### ⚠ WARNING

Towing vibrations will force the linch pins out unless they are properly locked in place over the verti-

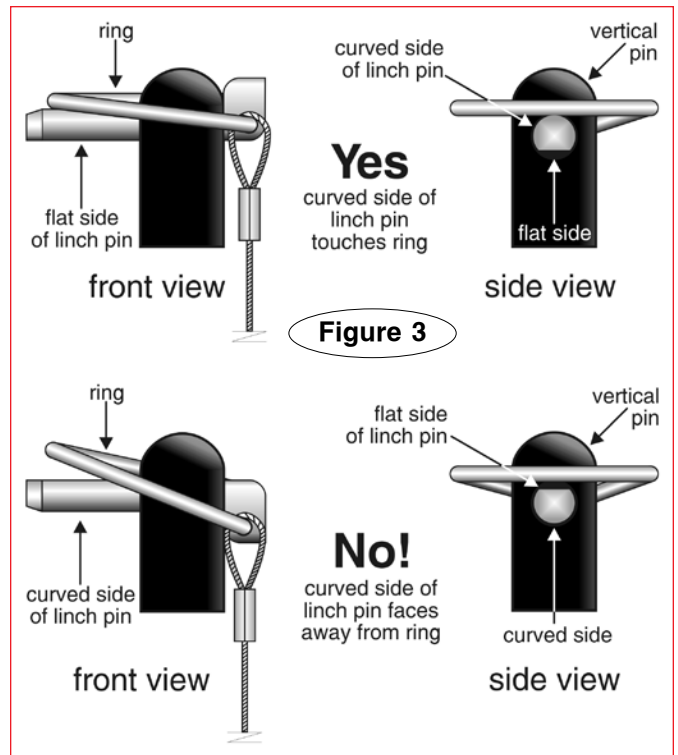

cal pins on both quick-disconnects. Refer to Figure 3.

Failure to properly attach and lock all linch pins will result in the loss of the towed vehicle, which may cause property damage, personal injury or even death.

## CONNECTING THE TOW BAR

### CAUTION

Use caution when handling the tow bar – if your hands, fingers or any part of your body are caught between moving components, they can be pinched, cut or otherwise injured.

1. Follow the preceding section in this manual – “Installing the ‘quick-disconnect’ system” – to attach the tow bar quick-disconnects (“QDs”) and the QD bases.

*Note: the quick-disconnect system is not used with ROADMASTER ‘MS’ or ‘MX’ series mounting brackets.*

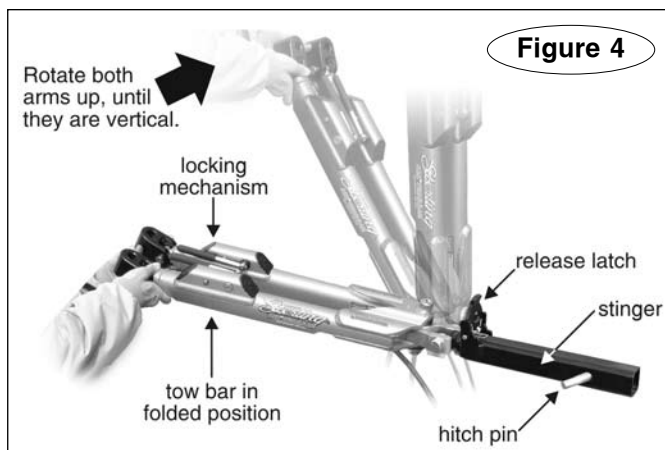

Instead, the tow bar is connected directly to the mounting bracket with the base pins and linch pins.

With this exception, the instructions below apply.

2. Drive the vehicle within three or three-and-a-half feet of the motorhome hitch receiver. The vehicle does not have to be perfectly centered to the hitch receiver, just close. Then, put the vehicle in gear (park), set the emergency brake and chock one of the wheels.

3. With the tow bar in the folded position (Figure 4), insert the stinger into the motorhome hitch receiver and attach the stinger to the hitch receiver with the hitch pin and clip (Figure 4).

### CAUTION

Attach the tow bar so that the locking mechanisms and the release latch are pointing up. Components of the tow bar may be damaged if the tow bar is attached with the release latch and the locking mechanisms pointing down.

4. Hold both tow bar arms firmly and rotate them up, so that they are vertical, as shown in Figure 4.

### ⚠ WARNING

Never release the tow bar arms when they are in

*continued on next page*

## Connecting the tow bar

*continued from preceding page*

**the vertical position. The arms can fall and cause severe personal injury.**

5. Push the release latch (Figure 5) forward, to bring both arms down to a horizontal position.

Standing to one side, swing both arms away from you. Then, align the holes in the outermost arm with the holes in one of the tabs on the quick-disconnect base (Figure 6).

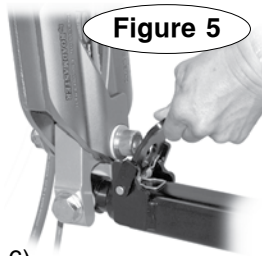

Attach the tow bar arm to the quick-disconnect base with one of the included base pins (Figure 6). Attach the arm so that the head of the shoulder bolt (Figure 6) is facing up. Lock the base pin with a linch pin (Figure 6) or optional padlock – part number 301 (one padlock) or 302 (two padlocks).

The linch pin must be locked. The ring (Figure 3) is spring-loaded – it must be snapped over the pin, as shown in Figure 3, with the curved side of the linch pin touching the ring, in order to keep the base pin secure.

### **WARNING**

**Both tow bar arms must be attached to the quick-disconnect bases and locked with a linch pin. Towing vibrations will force the linch pins out unless they are properly locked in place over the base pins on both quick-disconnect bases.**

**Failure to properly install and lock both base pins will result in the loss of the towed vehicle, which may cause property damage, personal injury or even death.**

6. Now, swing the other arm to the opposite side and connect it in the same manner.

7. Attach the safety cables and plug in the electrical wiring cord, according to the supplier's instructions.

Before towing the vehicle, be sure the steering is unlocked, the transmission is in the proper setting, and the emergency brake is released. Remove the wheel chock.

Check the manufacturer's specifications, the owner's manual or talk to the installer for the proper towing procedure(s) or requirement(s) for the vehicle to be towed.

### **WARNING**

**Do not tow the vehicle until the tow bar is attached with all pins or padlocks. Unless the tow bar is secured to both vehicles with all appropriate pins or padlocks, the vehicle will detach, which may cause property damage, personal injury or even death.**

When you drive away, steer briefly to the left and then to the right, to extend, self-center and lock the tow bar.

Always stop at this time. Check the tow bar to ensure that both arms are locked before assuming highway speed. Additionally, check the other components of your towing system, to ensure that they are fully engaged.

### **WARNING**

**Both tow bar arms must be locked before towing. If they are not, the momentum of the towed vehicle will apply excessive force to the tow bar arms and other components of the towing system, which may cause the towing system to fail, resulting in property damage, personal injury or even death.**

### **WARNING**

**Do not tow a vehicle using tow bar mounting brackets, safety cables or a hitch receiver rated less than the actual weight of the towed vehicle.**

**If the brackets, safety cables, hitch receiver or any supplementary towing equipment is not rated at the weight of the towed vehicle and all its contents, it may fail during towing, causing property damage, personal injury or even death.**

### **WARNING**

**If the motorhome hitch receiver has an extension, do not tow if the tow bar is more than three inches out of level.**

**Receiver extensions cause the towing system to swing much higher and lower than towing systems without extensions. This enlarged arc of motion creates excessive strain on the tow bar, brackets and frame, which can cause the towing system to fail, causing property damage, personal injury or even death.**

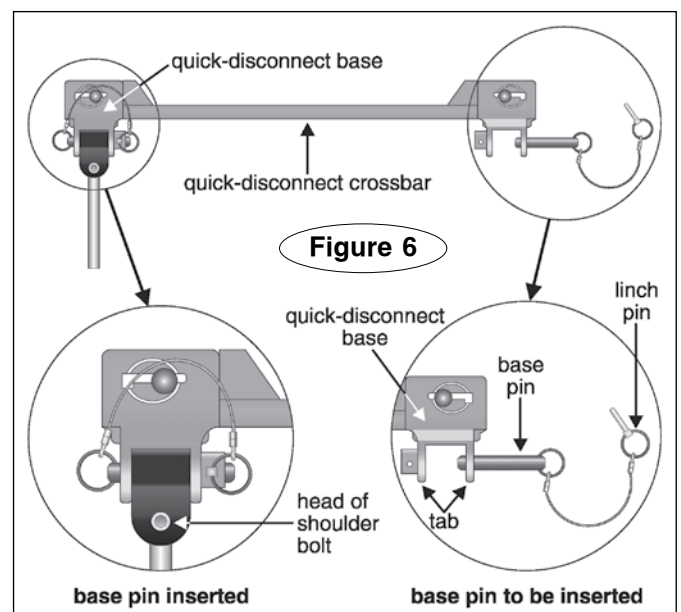

# DISCONNECTING THE TOW BAR

1. Disconnecting the tow bar is essentially the reverse of connecting it. First, always try to park on level ground, with the towed vehicle in line with the motorhome. This will eliminate most of the tension between the vehicles, allowing for an easier disconnect.

2. Disconnect the electrical wiring harness, safety cables and any other towing system accessories.

3. Lift the release handles on each tow bar arm (Figure 7) to release the locking mechanisms.

(Usually, one of the handles will require more pressure to release. This is the arm that has the majority of the tension between the two vehicles.)

## WARNING

**Always put the towed vehicle in gear (park), set the emergency brake and chock one of the wheels after lifting the release handles, and before removing the base pins. Failure to do so may result in a 'runaway' vehicle or may crush you between the towed vehicle and the motorhome, causing property damage, personal injury or even death.**

4. Put the towed vehicle in gear (park), set the emer-

gency brake and chock one of the wheels.

5. Remove the base pins and store the tow bar on the motorhome by reversing the connection procedure (under "Connecting the tow bar").

ROADMASTER recommends replacing at least one of the lynch pins with a padlock (part number 301, 302 or 308) to prevent accidental release or theft.

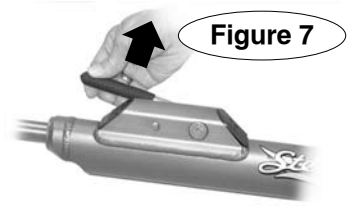

Figure 7

## CAUTION

The tow bar can be stored on the motorhome with the arms rotated to the left or the right. To avoid the possibility of damage to the bushings, rotate the arms away from the engine exhaust.

The bushings at the end of the tow bar arms can be warped by heat from the exhaust. If the bushings are warped, the tow bar arms will not slide easily, or they may not slide at all – it may be difficult to connect or disconnect the tow bar until the bushings are replaced.

# WIRING INSTRUCTIONS

The Sterling All Terrain tow bar comes equipped with a fully-wired motorhome-to-towed vehicle electrical cord – simply plug the cord into the sockets on the motorhome and the towed vehicle.

If you should need to rewire the plugs and sockets, follow the instructions below.

### Wiring the plug for a six-wire system

1. Insert the end of the electrical cord through one of the cable guides.

2. Use a test light to identify the wires conducting the brake, right turn, taillight, ground and left turn signals.

3. Strip ¼" to 3/8" of insulation from the ends. Connect the wires according to Figure 8; apply a silicone sealant to the attachment points to help prevent damage from moisture and corrosion.

### Wiring the socket for a six-wire system

1. If necessary, find a suitable location to install one of the electrical socket brackets on the front of the towed vehicle, in reach of the existing six-wire harness. The bracket must be attached close to the center, and to a surface of sufficient strength to hold it firmly in place.

## CAUTION

**Attach the mounting bracket close to the center of the towed vehicle. If the bracket is attached too far to either side, the bracket and the electrical socket may be pulled away when the motorhome turns.**

2. Strip ¼" to 3/8" of insulation from the ends of the wires.

Loosen the set screw at the back of the socket and push the inner connector out the front. Then run the six-wire electrical cord through the back of the protective boot and the housing.

3. Loosen all of the set screws on the side of the socket, and connect the wires to the back of the socket as shown in Figure 9.

*continued on next page*

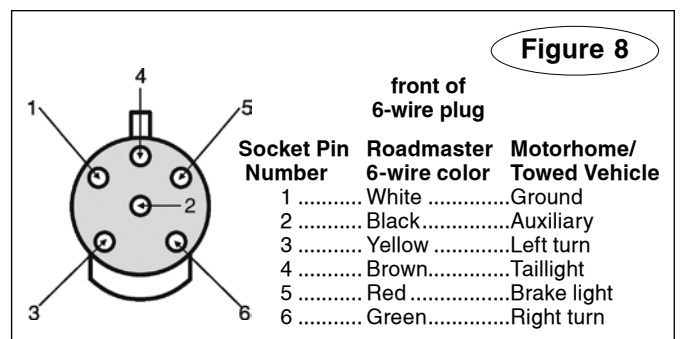

Figure 8

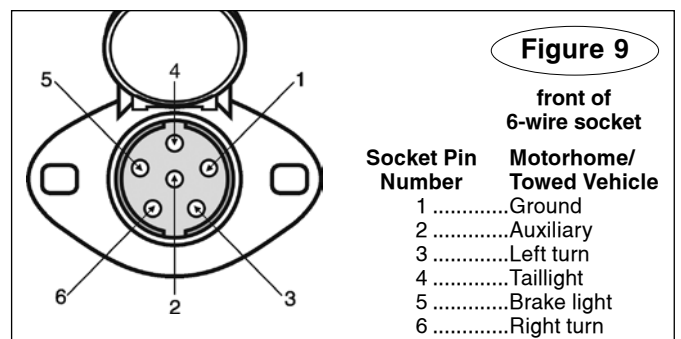

Figure 9

## Wiring instructions

continued from preceding page

4. Tighten all the set screws and check each wire to ensure that it is fastened securely. Apply a clear silicone sealant around each wire entry and set screw indentation to help weatherproof the socket and secure the set screws.

5. If the motorhome does not have the correct wiring socket already, you can replace it with the new socket for the six wire cord, and connect the appropriate wires to the new socket, according to Figure 9.

6. Connect the four-wire electrical cord to the motorhome and towed vehicle. Test the towed vehicle's turn signals, tail lights and brake lights to ensure they operate in conjunction with those of the motorhome.

### WARNING

**If the plugs and sockets are not properly wired, the electrical connection will not function, and the towed vehicle's turn signals and brake lights will not mimic those of the motorhome. Drivers behind the towed vehicle will not be alerted by turn signals or brake lights, which may result in a traffic accident, causing property damage, personal injury or even death.**

### Wiring the plug for a seven-wire system

1. Use a test light at the motorhome socket to verify that the terminals are conducting the electrical signals as identified in Figure 10.

2. Next, loosen the set screw and remove the terminal assembly from the plug housing.

3. Slide the included ½" clear vinyl spacer over the end of the wiring, and pull it back six inches.

4. Run the wiring through the housing. Connect the wires according to Figure 11.

Disregard the color code printed on the back of the plug; use the pin number-to-ROADMASTER wire color code in Figure 11.

Tighten all the set screws and check each wire to ensure that it is secure. Apply a clear silicone sealant around each wire entry and set screw indentation to help weatherproof the socket and secure the set screws.

5. Align the keyway at the top of the terminal assembly to the housing key and insert the assembly back into the housing. Push the clear vinyl spacer forward until it is flush to the end of the housing, then tighten the strain relief screw to secure the assembly. Tighten the set screw.

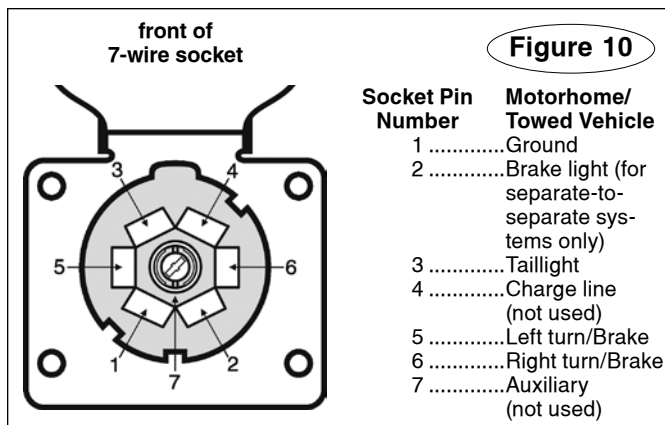

### Wiring the socket for a seven-wire system

1. If the motorhome does not have an electrical socket, find a suitable location to install an electrical socket bracket (optional) on the rear of the motorhome. The bracket must be attached close to the center, and to a surface of sufficient strength to hold it firmly in place.

### CAUTION

**Attach the mounting bracket close to the center of the towed vehicle. If the bracket is attached too far to either side, the bracket and the electrical socket may be pulled away when the motorhome turns.**

2. First loosen the set screws on the connector and remove the socket from the housing.

Run the wiring through the housing, then strip ¼" to 3/8" of insulation from the ends. Connect the wires according to Figure 10.

Tighten all the set screws and check each wire to ensure that it is fastened securely. Apply a clear silicone sealant around each wire entry and set screw indication to help weatherproof the socket and secure the set screws.

Align the socket keyway to the housing key and insert the socket back into the housing; tighten the set screws.

3. Connect the electrical cord to the motorhome and towed vehicle. Test the towed vehicle's turn signals, taillights and brake lights to ensure they operate in conjunction with those of the motorhome.

### WARNING

**If the plugs and sockets are not properly wired, the electrical connection will not function, and the towed vehicle's turn signals and brake lights will not mimic those of the motorhome. Drivers behind the towed vehicle will not be alerted by turn signals or brake lights, which may result in a traffic accident, causing property damage, personal injury or even death.**

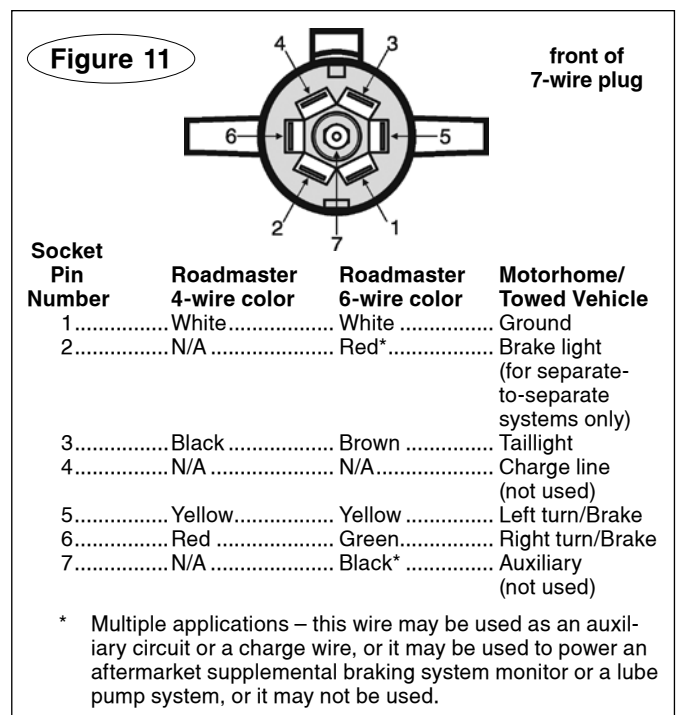

# HOW TO USE SAFETY CABLES

---

Safety cables are an integral part of your towing system. They are a secondary safety device, required by law in many states. This section and the following section will acquaint you with how to use them properly.

- The safety cables must connect the towing vehicle to the towed vehicle, frame to frame.
- The safety cables must be rated at 6,000 pounds weight capacity per pair, or higher. This is the maximum weight capacity of the tow bar – the towed vehicle and all its contents cannot exceed 6,000 pounds.
- Pull the safety cables so that all the slack is at the motorhome. **Make sure there is enough slack in the cables at the motorhome to allow for sharp turns** – if there is not enough slack, the towing system will be severely damaged when the motorhome turns a sharp corner.
- The safety cables must be the correct length...
  - Make sure the cables are not too short – if you use a receiver hitch extension or other equipment that extends the distance between the towed vehicle and the motorhome, the standard cables may be too short. If the cables are too short, the towing system will be severely damaged when the motorhome turns a sharp corner.

(Safety cable extensions in a variety of lengths are available from ROADMASTER.)

- Make sure the cables are not too long – the cables

should not hang down to the extent they may catch on obstructions, or drag on the ground. This much slack could cause damage to the towing system, the towed vehicle, or the motorhome.

If the cables are too long, wrap the excess cable around the tow bar to take up the slack. **Make sure there is enough slack in the cables at the motorhome to allow for sharp turns.**

Damage caused by using safety cables of an incorrect length is not covered under warranty.

- Always cross the cables under the hitch receiver, as shown in Figure 12. In the unlikely event the tow bar separates from the motorhome, crossing the cables will help prevent the tow bar from dragging on the ground, which can cause the tow bar to “pole vault” the towed vehicle.
- Some ROADMASTER tow bar mounting kits with removable arms use two safety cables on each side. If two sets of safety cables are required, both must be used. This is required by law. Refer to “Proper installation of safety cables” for further information.

## **WARNING**

**Failure to follow these instructions may cause property damage, personal injury or even death.**

# PROPER INSTALLATION OF SAFETY CABLES

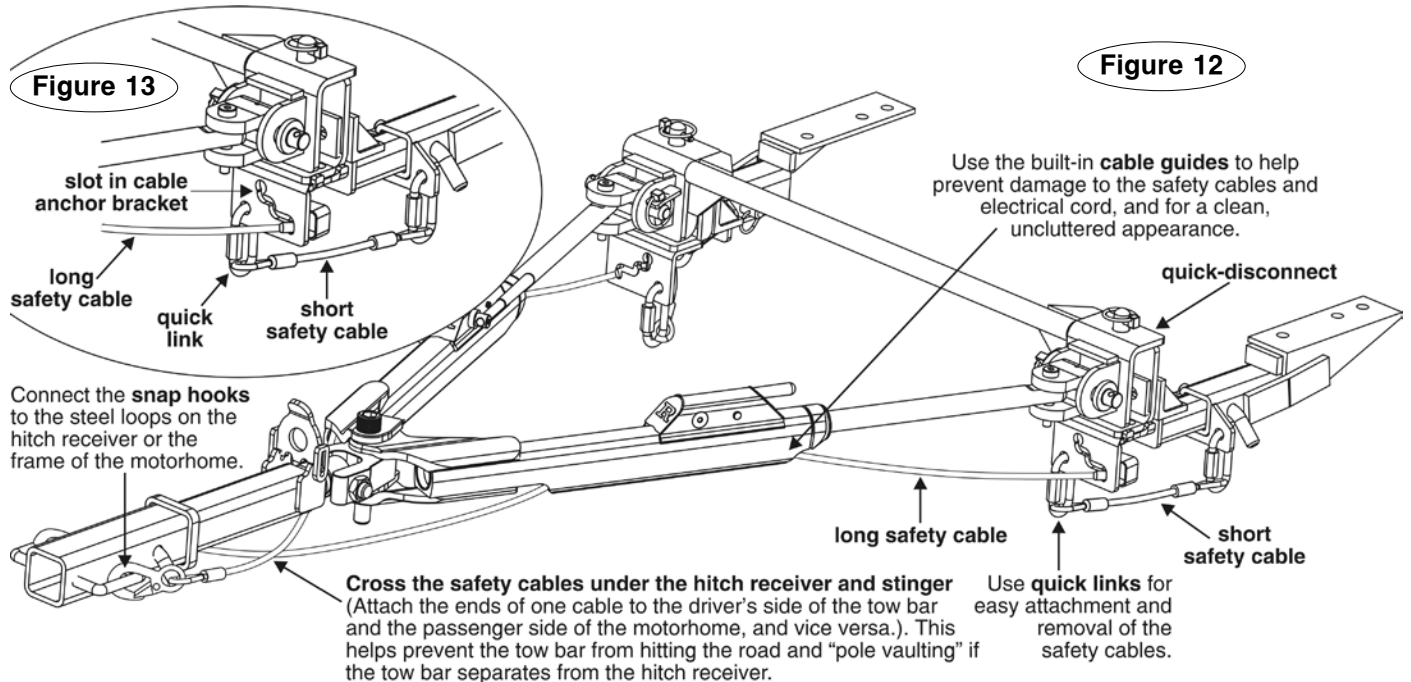

Some ROADMASTER tow bar mounting brackets with removable arms, such as the ones in Figures 12 and 13, use both a long safety cable and a short safety cable on each side. Each **long safety cable** runs from the towing vehicle to a **cable anchor**. Connect each long safety cable to a cable anchor by inserting it through the top of the slot in the cable anchor bracket and dragging it down.

Both ends of the **short safety cables** are connected by **quick links**. One quick link is attached to the mounting bracket and one is attached to the cable anchor.

Unscrew the nuts on each quick link to connect the safety cable loops. Finger-tighten the nuts firmly, until the loop is completely closed, to secure the attachment.

Do not substitute carabiners or other devices for the quick links – the quick links are designed to hold the weight of a towed vehicle; carabiners or other devices are not.

Only ROADMASTER bracket kits with removable arms have these short safety cables. Other bracket kits are bolted directly to the frame of the towed vehicle and do not require short safety cables. If your ROADMASTER bracket kit contains short safety cables, refer to the installation instructions for complete information.

## **WARNING**

The safety cables must be carefully routed so that they cannot become pinched, frayed, scraped or otherwise damaged, and so they will not drag when going over dips or low spots.

Do not use the cables if they show any signs of wear or damage – immediately discontinue towing and replace the cables.

Failure to follow these instructions will result in cable failure, which may cause property damage, personal injury or even death.

## **WARNING**

If the quick links are not completely tightened, with the loop closed, the safety cables may detach. In the event of a towing system failure, the towed vehicle will detach, which may cause property damage, personal injury or even death.

## **WARNING**

If your towing system requires two sets of safety cables, always use both the long and the short safety cables. Connect them as shown in Figures 12 and 13. Otherwise, in the event of a towing system failure, the towed vehicle will detach, which may cause property damage, personal injury or even death.

## STAY WITHIN THE 'SAFE ZONE'

Towing with a motorhome-mounted tow bar which has an upward or downward slope puts undue strain on the entire towing system. For that reason, **do not tow if the tow bar is not within the 'Safe Zone' – no more than three inches above or below level.**

Towing a vehicle with a tow bar that is not within the Safe Zone will result in significant wear and tear on the tow bar and brackets, significant wear and tear on the vehicle's suspension and frame, and the eventual failure of the towing system.

To determine if the tow bar is within the Safe Zone – first, connect the motorhome and towed vehicle on level ground. Next, measure the distance from the center of the motorhome receiver down to the ground. Then, measure the distance from the center of one of the base pins down to the ground.

Compare these two measurements. To be within the Safe Zone, they cannot be more than three inches apart if the base pin is above or below the motorhome hitch receiver. See Figure 14.

If the tow bar is not within the Safe Zone, you must purchase a hitch accessory to raise or lower the hitch receiver. ROADMASTER has three accessories available – Hi-Low Hitches, Hi-Low Drops and Dual Hitch Receivers – which will raise or lower the hitch receiver from two to 10 inches, depending on the model.

Towing with the tow bar more than three inches above or below level will void the ROADMASTER warranty.

### WARNING

**Failure to follow these instructions may cause property damage, personal injury or even death.**

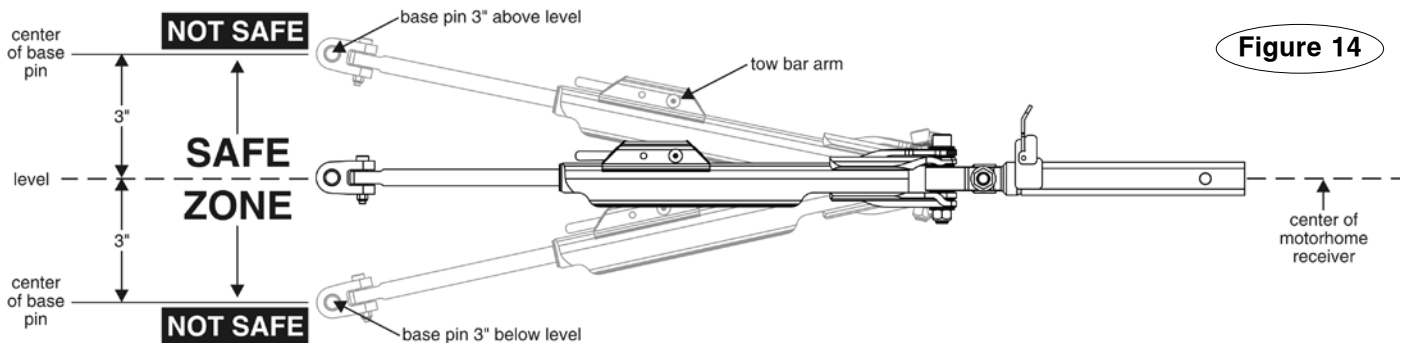

## CARE AND CLEANING

As is the case with most precision equipment, frequent cleaning and care results in better performance and longevity. Use the following guidelines to keep your tow bar clean and well-lubricated.

Always clean the tow bar before lubricating. Use a water-soluble cleaner such as Voom RV (part number 9911) – it does an exceptional job of breaking down road film, dirt and grease.

Clean all moving parts, paying special attention to the tow bar arms and the locking mechanisms. No matter what part you're cleaning, the method is the same – 1) spray a liberal amount of cleaner over it; 2) work the component back and forth to work out any accumulated dirt; 3) wipe it down; and 4) repeat until clean.

To clean one of the tow bar arms, first remove the two rubber caps at either end of the locking mechanisms (Figure 15). Then raise the arm and spray cleaner at the top of the inner/outer arm assembly (Figure 16).

Raise the tow bar arm and work the arm up and down to flush out dirt from the bottom of the assembly. Wipe the dirt off and repeat until the arm is clean.

Repeat for the other arm.

### CAUTION

**Do not use petroleum-based products to clean or lu-**

**bricate the tow bar. Petroleum will attract dirt and dust, which will impede the operation of the sliding arms and/or other components. Certain petroleum products may also corrode non-metallic components.**

**Damage caused by using a petroleum-based product to clean or lubricate the tow bar is not covered under warranty.**

After cleaning the tow bar, wipe any remaining clean-  
*continued on next page*

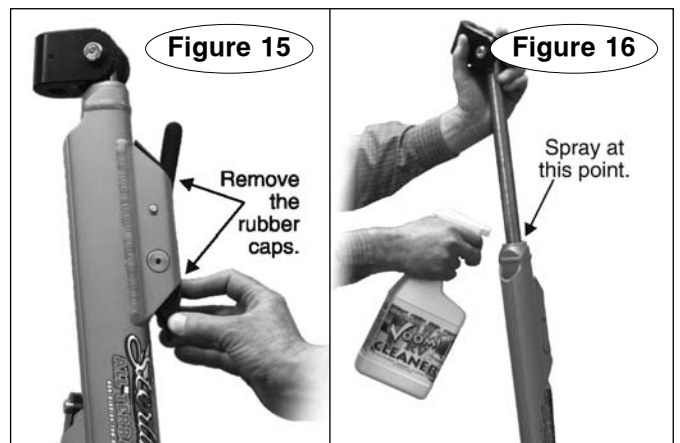

## Care and cleaning

*continued from preceding page*

er away.

To clean one of the locking mechanisms, first spray cleaner into the mechanism, then raise the tow bar arm. Move the release handle up and down to flush out dirt from the bottom of the assembly.

Close the arm. This will bring the internal locking components close to the opening that was covered by the rubber caps.

Spray cleaner through the opening and over the locking mechanism, then use a wire brush to remove any dirt. Repeat until the locking mechanism is clean. Allow the mechanism to air dry.

Repeat for the other locking mechanism.

Now that you have a clean, dry tow bar, use a dry silicone aerosol, such as LubeMaster (part number 747), to lubricate the tow bar – spray a liberal amount of the silicone into all moving parts. LubeMaster sprays on wet, then dries in seconds. After the lubricant has dried, flex

the tow bar components, to work the lubricant in.

Spray silicone lubricant inside both of the locking mechanisms. After the lubricant has dried, move the release handles up and down to work the lubricant in

## CAUTION

**Always clean the locking mechanisms, as described above, before lubricating them. Silicone coats and covers in a thin layer. If it is not removed, it will reduce the clearance for the locking mechanisms, preventing proper operation.**

**Extended storage** – before storing your tow bar for an extended period of time, be sure to clean and lubricate it as above. Store the tow bar in its cover (optional, part number 057-2), to protect it from the elements.

*Note: to remove scratches and restore luster on the stainless steel arms, we suggest that you use extra fine (0000) steel wool, 3M “Scotch Brite” (fine pad) or a similar product.*

## LIMITED WARRANTY

### 1. WARRANTY

#### 1a. WARRANTY OF CONFORMITY AT TIME OF SALE

ROADMASTER, Inc. warrants that at the time of sale of this product it will be free from defects in material and manufacture and will conform to ROADMASTER'S specifications for the product.

#### 1b. CONDITIONAL ONE-YEAR WARRANTY

In addition to the preceding time-of-sale warranty, if the product registration card is completely and accurately filled out and mailed to ROADMASTER within thirty (30) days of purchase, ROADMASTER will provide an additional warranty that for a period of one year after sale the product will remain in good working order, PROVIDED THAT the product is installed and maintained in accordance with ROADMASTER'S instructions and is not subjected to: (a) alteration or unauthorized repairs or repairs by anyone other than ROADMASTER or a ROADMASTER-authorized service center, (b) misuse, abuse, commercial use, or improper maintenance, (c) Acts of God (including without limitation hurricanes, tornadoes, floods, or other severe weather or natural phenomena), (d) failures due to products not supplied by ROADMASTER, or (e) other treatments, uses, or installations for which the product was not intended. This warranty extends only to the first retail purchaser-consumer of the product and is not transferable.

**EXTENDED WARRANTY PERIOD:** If ROADMASTER receives the product registration card, completely and accurately filled out, within thirty (30) days of purchase, ROADMASTER will enlarge the one-year warranty period in the preceding paragraph to a period of two years.

#### 2. DISCLAIMER OF OTHER WARRANTIES

The preceding warranties are the exclusive and sole express warranties given by ROADMASTER. They supersede any prior, contrary or additional representations, whether oral or written. No agent, representative, dealer or employee has the authority to alter or increase the obligations or limitations of this warranty. Any implied warranties, including the WARRANTY OF MERCHANTABILITY and any WARRANTY OF FITNESS FOR A PARTICULAR PURPOSE, are limited in duration to thirty days or the term of the applicable express warranty provided above, whichever is longer.

Some states do not allow limitations on how long an implied warranty lasts, so the above limitation may not apply to you.

#### 3. EXCLUSIVE REMEDY FOR ANY NONCONFORMITIES

If during the applicable Warranty Period, the product does not conform to the preceding Warranties, notify ROADMASTER as provided below, and within a reasonable time ROADMASTER will provide, at its option, one of the following: (1) replacement components for any nonconforming or defective product or components or (2) the percentage of the purchase price for the nonconforming product equal to the percentage of the Warranty Period remaining when ROADMASTER is notified of the nonconformity. ROADMASTER will, at its option, (a) use new and/or reconditioned parts in performing warranty repairs and making replacement products, (b) use parts or products of original or improved design in the repair or replacement. If ROADMASTER repairs or replaces a

product, its warranty continues for the remaining portion of the original Warranty Period or 60 days from the date of the return shipment to the customer, whichever is greater. All replaced products and all parts removed from repaired products become the property of ROADMASTER. ROADMASTER will not provide, and will not be liable for, labor, costs of removal or reinstallation of components, disposal, shipping, freight, taxes, or other incidental charges.

#### THESE REMEDIES ARE THE EXCLUSIVE AND SOLE REMEDIES FOR ANY BREACH OF WARRANTY.

For any breach of warranty, the Owner must telephone ROADMASTER at 1-800-669-9690 within thirty (30) days after discovering the nonconformity. Do not return any product without first calling ROADMASTER and getting a return authorization number. Returned products must include the return authorization number and a copy of the original invoice, bill or other proof of the date of purchase. The date of purchase must coincide with the original warranty registration card on file. ROADMASTER will authorize (a) shipment of the product to ROADMASTER or (b) repair or replacement at the nearest warranty service center—in both cases with shipping at your expense. Do not purchase replacement parts or pay for repair labor—you will not be reimbursed. Compliance with the requirements of this paragraph is a condition to coverage under the Warranty: if these requirements are not complied with, ROADMASTER will have no obligation to provide any remedy for any breach of warranty.

#### 4. DISCLAIMER OF INCIDENTAL AND CONSEQUENTIAL DAMAGES

IN NO EVENT SHALL ROADMASTER BE LIABLE FOR ANY INCIDENTAL, SPECIAL, INDIRECT OR CONSEQUENTIAL DAMAGES, WHETHER RESULTING FROM NONDELIVERY OR FROM THE USE, MISUSE OR INABILITY TO USE THE PRODUCT OR FROM DEFECTS IN THE PRODUCT.

Some states do not allow the exclusion or limitation of incidental or consequential damages, so the above limitation may not apply to you.

#### 5. APPLICABLE LAW

This Warranty will be interpreted, construed, and enforced in all respects in accordance with the laws of the State of Washington, without reference to its choice of law rules. The U.N. Convention on Contracts for the International Sale of Goods will not apply to this Warranty.

#### 6. SEVERABILITY

If any provision of this warranty is found to be invalid or unenforceable, then the remainder shall have full force and effect, and the invalid provision shall be partially enforced to the maximum extent permitted by law to effectuate the purpose of the agreement.

#### 7. ADDRESS FOR NOTICES TO ROADMASTER

ROADMASTER, Inc., 6110 NE 127th Ave, Vancouver, WA 98682

This warranty gives you specific legal rights, and you may also have other rights which vary from State to State.

# We're the suspension experts

Very few people would say they bought their motorhome (or truck, van or SUV) for the suspension. For most of us, the suspension is out of sight and out of mind – even though your driving performance, safety and comfort are all riding on those components.

Unequal weight distribution, worn or inadequate components, excessive axle side play or a higher center of gravity can quickly overpower a stock suspension, even in everyday driving. Unfortunately, finding a solution can be just as frustrating as dealing with the consequences.



for more information...

Call 800-669-9690, or visit [www.roadmasterinc.com](http://www.roadmasterinc.com)

## The primary benefits of ROADMASTER suspension components are...

- **Anti-sway bars** – virtually eliminate ‘body roll’ (the vehicle rolls from side to side, especially during cornering). Anti-sway bars stabilize the vehicle, keeping it level through crosswinds and dramatically improving overall handling.
- **Steering stabilizers** – front tire blow out protection. Stabilizers also automatically compensate for oversteer caused by pot holes, rut tracks and other unfavorable road conditions.

- **Trac bars** – drastically reduce ‘wander’ (the steering feels loose, making it difficult – and physically exhausting – to keep the vehicle in a straight line).

Each of these components will **protect your vehicle** (improved tire life, reduced suspension wear, reduced maintenance costs and improved vehicle performance) and **protect your family** (better driving control, reduced driver fatigue, more control in evasive maneuvers and improved driver confidence).

## Every ROADMASTER suspension component...

- ...is designed as a custom fit, for a specific chassis. ROADMASTER engineering designs take into consideration chassis and axle manufacturers’ specifications (your warranty will not be affected).

*continued on next page*

## Do you need a custom suspension component?

Every “yes” to the following questions is a “yes” for an anti-sway bar, a steering stabilizer and/or a trac bar...

- Does the vehicle “roll” when cornering?
- Does driving for an extended period of time leave you physically exhausted?
- Is your rig all over the road – can’t keep it between the lines?
- Would you lose control if one of the front tires blew out?
- Does the steering wheel have a mind of its own?
- Do passing 18-wheelers and crosswinds rock your vehicle back and forth?
- Is driving a ‘white knuckle’ experience?

## Suspension Product Benefit Comparison

Suspension Product Benefit Comparison	Shock Absorbers	Air Bags	RSS Anti-Sway Bar	Bell Crank	Davis TruTrac Bar	Generic Steering Dampener	Reflex Steering Stabilizer
Bouncing	X						
‘Porpoising’ (up and down movement)	X						
Rough Ride	X	X					
Sway (‘body roll’)			X				
Soft Steering			X	X	X	X	X
Wind Buffeting (crosswinds, wind gusts, passing 18-wheelers)			X		X		X
Wander				X	X		X
Rut Tracking					X		X
Blow Out Protection						X	X
Load Leveling		X					

There are several components that make up a good vehicle suspension system: shocks provide comfort; air bags support weight; anti-sway bars control left-to-right sway; trac bars reduce ‘wander;’ and steering stabilizers provide blow out protection. Use this chart to make an informed decision about what aftermarket suspension product(s) will enhance your vehicle’s stability, handling and maneuverability.

## We're the suspension experts

*continued from preceding page*

### Which component is right for you?

ROADMASTER designs, engineers and manufactures anti-sway bars, trac bars, and steering stabilizers for both original equipment manufacturers and the aftermarket. Anti-sway bars, trac bars and steering stabilizers work in concert with the other components of your suspension system to add stability and control.

Each of these components has a specific role to play.

The graph on the previous page identifies the primary benefits of aftermarket suspension products. Each one has value – for a specific application. It's important to understand and identify what you're experiencing, so you can select the correct product solution.

## RSS Anti-Sway Bars

A remarkable improvement in stability and cornering control – for motorhomes or any large vehicle, especially towing combinations – is just a few bolts away. Anti-sway bars from Roadmaster Suspension Solutions deliver a "Wow!" difference in RV control you'll notice the first time you turn the wheel.

- **20 years of experience** in the RV industry
- for **motorhomes, trucks, vans and SUVs**
- more than 100 kits, each one **custom-designed** for a specific chassis and suspension system
- large diameter, cadmium-plated **4140 chromoly steel bars**, with heavy-duty **polyurethane bushings**
- **easy installation** – in most cases, eight bolts

### What do our customers say?

*"I noticed a difference as soon as I stepped into the motorhome – there was no rocking movement.*

*During a recent trip we encountered substantial crosswinds. With the RSS anti-sway bar, I estimate our motorhome's sway was reduced by 90 percent.*

*We don't feel anything now when a tractor trailer blows by us.*

*I'm 100 percent satisfied – everyone should experience the benefit of this product."*

*– Johnny Singleton, Myrtle Beach, South Carolina*

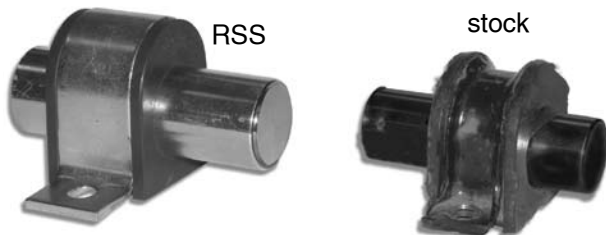

**A HIGH-GRADE ALLOY AND A BETTER PIVOT POINT** – The stock anti-sway bar (on the right) has a small diameter, 1020 grade spring steel, and a rubber bushing. The RSS anti-sway bar (to the left) has a large diameter, 4140 chromoly steel and a polyurethane bushing, making it many times more resistant to sway.

## Reflex Steering Stabilizers

Your best insurance against the catastrophic consequences of a front tire blow out is a Reflex steering stabilizer.

When you blow out a front tire, your vehicle will make an abrupt turn toward that tire, causing you to veer into oncoming traffic or off the road. The Reflex steering stabilizer's tempered steel springs, which are attached to the tie rods and undercarriage, automatically compensate for oversteer caused by front tire blow outs, pot holes, rut tracks and other unfavorable road conditions, as well as crosswinds and passing 18-wheelers.

The springs react instantaneously to bring the vehicle back to center.

### What do our customers say?

*"I had a Reflex Steering Stabilizer installed, and the difference was night and day – my Class C motorhome handles like a sports car. The stabilizer keeps the steering centered, no matter what the road throws at me. Ruts, bumps and hairpin curves are no problem.*

*My steering wheel doesn't belong to potholes any more – it belongs to me."*

*– Jerry Miller, Portland, Oregon*

## Davis TruTrac™ Bars

Does your motorhome vibrate from side to side? Are "wandering," "rut tracking" and "lazy steering" a problem? Tired and fatigued trying to keep in line going down the road?

Davis TruTrac bars link the chassis to the front axle, eliminating excessive axle side play, without affecting normal up-and-down suspension travel.

The result is precise, predictable handling. The benefits are an immediate improvement in both vehicle performance and safety, as well as increased driver comfort – more positive control means less driver fatigue.

### What do our customers say?

*"My F53 chassis would vibrate so bad that it shook the whole motorhome. The only way to stop the vibration was to slow down to 20 mph – which almost got me rear-ended twice. Finally my wife told me, 'I'm not riding in that motorhome any more.'*

*A mechanic told me about Davis TruTrac bars. I had one installed and the vibrations stopped immediately. I drove that motorhome for another 150,000 miles (with my wife back on board) and it was solid as a rock."*

*– John Kielty, Reno, Nevada*

# STERLING ALL TERRAIN COMPONENTS

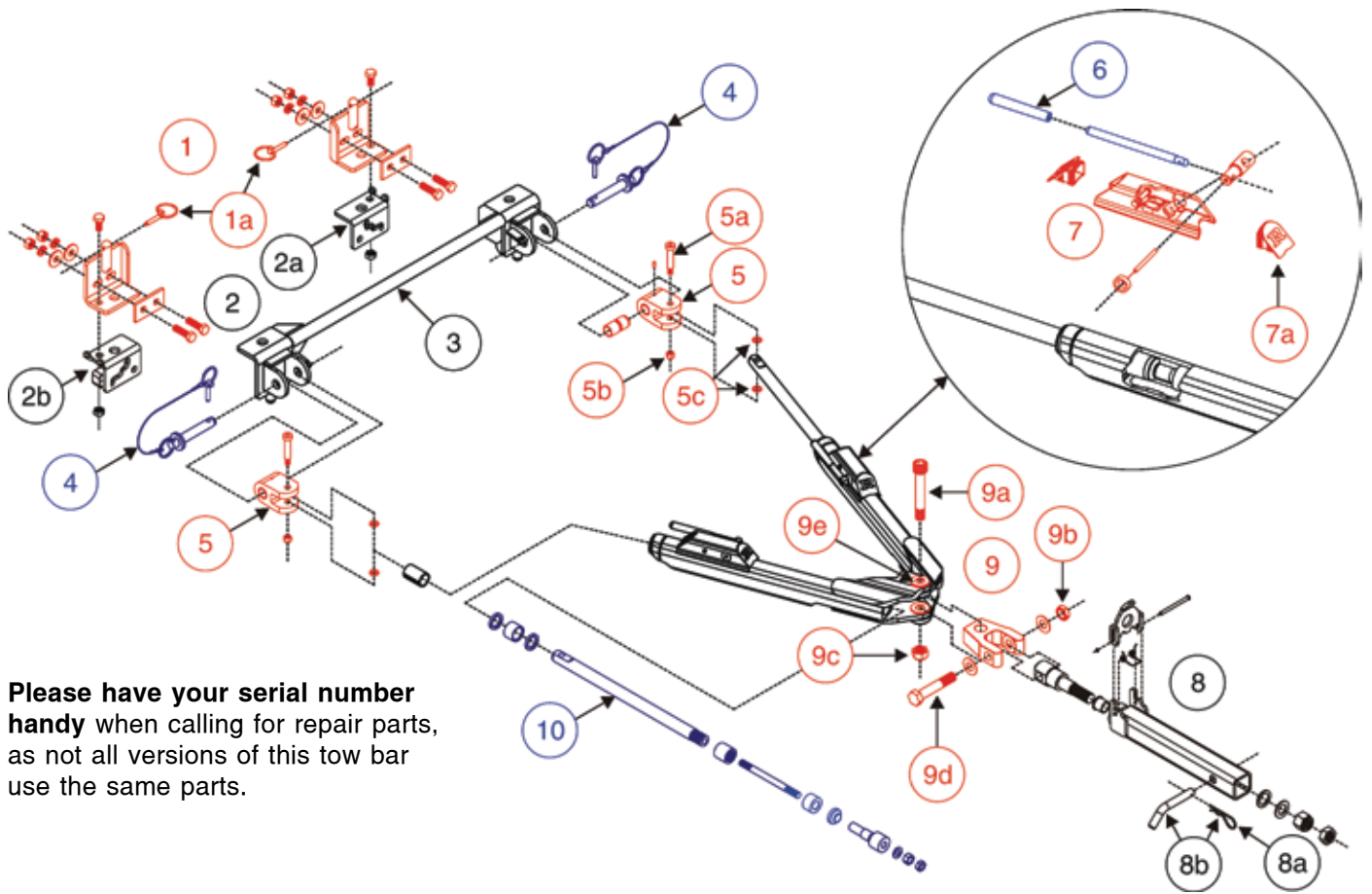

Please have your serial number handy when calling for repair parts, as not all versions of this tow bar use the same parts.

<i>description</i>	<i>part number</i>
<b>1</b> quick-disconnects, complete car side set (color-coded red).....	222
<b>1a</b> linch pins (two).....	910024
<b>2</b> safety cable anchor brackets, complete set – driver’s and passenger side (color-coded black) .....	910653
<b>2a</b> driver’s side only.....	910653-01
<b>2b</b> passenger side only.....	910653-02
<b>3</b> quick-disconnect crossbar <b>only</b> .....	067
quick-disconnect crossbar <b>assembly</b> (color-coded red, blue and black; includes 1, 3 and 4).....	910021-00
<b>4</b> base pin, cable and linch pin (two each; color-coded blue) .....	910029
<b>5</b> swivel ear assembly, one each – includes part numbers 5a, 5b and 5c (color-coded red).....	910661
<b>5a</b> ½" x 2" screw.....	350376-00
<b>5b</b> nylon lock nut.....	350255-00
<b>5c</b> ½" nylon washer .....	350356-00
<b>6</b> Freedom Latch lock handle and rubber grip (color-coded blue) .....	750600
<b>7</b> Freedom Latch spring replacement kit with latch caps – contains four latch caps (part number 7a), and two springs and two snap rings (not shown) – color-coded red.....	910652
<b>7a</b> latch cap only.....	200460-00
<b>8</b> stinger assembly, complete (color-coded black; part numbers 8a and 8b sold separately) .....	910019-40
<b>8a</b> hitch pin clip (two).....	910028
<b>8b</b> hitch pin and clip (one each) .....	910027

<i>description</i>	<i>part number</i>
<b>9</b> yoke assembly with bushing (color-coded red; part numbers 9a through 9e sold separately) .....	910575
<b>9a</b> ¾" x 4¾" bolt .....	350190-20
<b>9b</b> ¾" jam nut.....	350264-10
<b>9c</b> ¾" lock nut.....	350267-01
<b>9d</b> ¾" x 4-1/8" bolt .....	350191-00
<b>9e</b> ¾" nylon washer (one each; 13 necessary for complete tow bar).....	350358-00
<b>10</b> inner arm assembly, driver’s and passenger side (color-coded blue) .....	910660-10

## NOT SHOWN

- 4-wire straight electrical cord..... 98164
- 6-wire straight electrical cord..... 98146
- 7-wire to 6-wire straight electrical cord..... 98146-7
- 7-wire to 4-wire straight electrical cord..... 98164-7
- 4-wire electrical cable with one 4-wire plug..... 650814
- 6-wire electrical cable with one 6-wire plug..... 650816
- 4-wire socket only .....
- 6-wire socket only .....
- 7-wire plug only .....
- 68" 6,000-pound capacity EZ Hook safety cables (pair) – included with Sterling All Terrain .....
- 76" 6,000-pound capacity EZ Hook safety cables (pair) – for towing combinations with accessories which extend the length of the towing system.....